

Absolute, Non-Contact Positions Sensors

MH-Series Analog Redundant

Document Part Number
551218 Revision F

Temposonics MT
Measuring length 50 - 2500 mm



Redundant Sensor for Mobile Hydraulics

- Redundant Sensor System
- Linear, Absolute Position Sensors
- Non-Contact Sensor Technology with Highest Durability
- Superior Accuracy: Linearity Tolerance < 0.04 % F.S.
- Hysteresis ± 0.1 mm
- Direct Analog Displacement Output: Current or Voltage
- Power Supply: 12/24 VDC
- Shock Rating 100 g (single hit) / IEC 68-2-27
- Vibration Rating 15 g / 10-2000 Hz / IEC 68-2-6

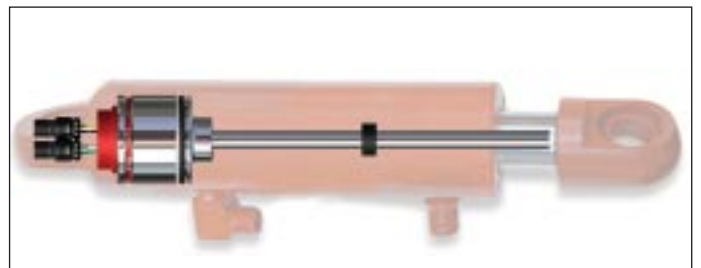

Designed for the mobile world

MH-Series sensors were designed with the "mobile" world in mind, and have been validated in the field by customers worldwide. They are available with a redundant output for safety sensitive applications. Performance is second to none; high accuracy, position output. Ruggedness is "designed in"; 100 g shock rating. Cable and wire options are sized for direct connection to proven connectors. The model MT sensor can be fully sealed and embedded in a cylinder to ensure a long operating life.

Temposonics MT

Analog Redundant

Magnetostriction

The absolute **Temposonics**® linear position sensors are based on the MTS developed magnetostrictive measurement principle. That combines various magneto-mechanical effects and uses the physical height precise speed-measurement of an ultrasonic wave (torsion pulse in its sensor element) for position detecting. Sensor integrated signal processing transforms the measurements directly into market standard outputs. The contactless principle - an external movable magnet marks the position - eliminates the wear, noise and erroneous signal problems and guarantees the best durability without any recalibration.

Measuring Principle

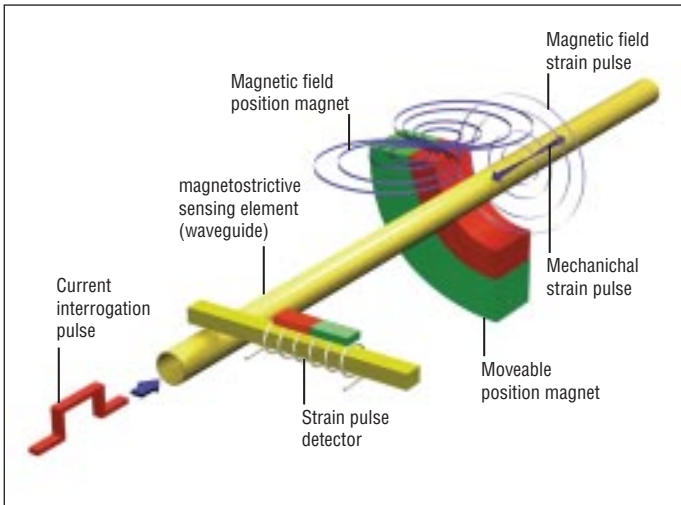

Measuring Principle (simplified illustration)

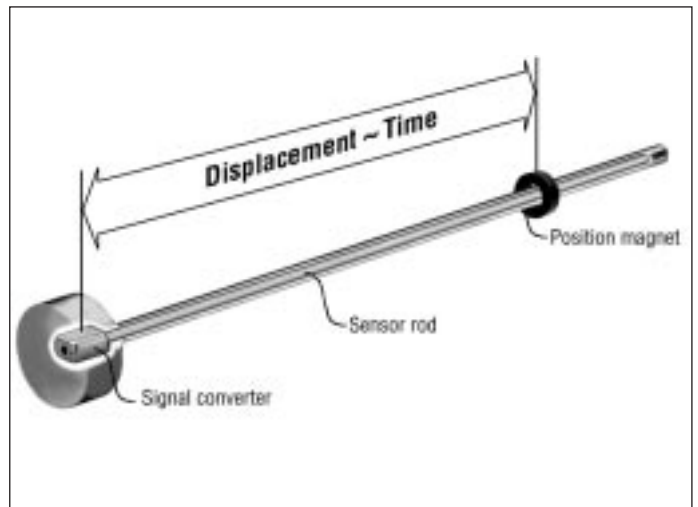

Temposonics®-MT - Redundant Sensor for Mobile Applications Measuring Range 50 - 2500 mm.

The robust Temposonics MT sensor's stainless steel housing is designed for direct stroke measurement in compact standard hydraulic cylinders. MT type sensors are ideal choices for a wide range of hydraulic cylinders. Magnetostrictive displacement sensors, high quality cylinders and precise control valves form ideal driving systems for technically demanding of mobile hydraulics.

Simple Mechanics

The extremely rugged sensor consist of 3 main parts and has two independent sensors "embedded" in one single housing.

- The flange housing with independent signal converter and built-in electronics
- The pressure-proof sensor pipe (up to 350 bar) with flange, fits into the bored piston rod, protects two internal sensing elements, the waveguide systems.
- The position magnet, only moving part, is mounted on the piston bottom. This permanent magnet travels wearfree and contactless along the stationary sensor tube.

Technical Data

Input

Measured variables:	Displacement
Measuring range:	50 - 2500 mm in 5 mm steps

Output

Signal characteristic:	Continuously analog output restricted by noise or A/D converter of control unit	
Voltage:	0.25...4.75 VDC	inverse: 4.75...0.25 VDC
	0.5...4.5 VDC	inverse: 4.5...0.5 VDC
Current:	4...20 mA	inverse: 20...4 mA
Resolution:	typ ± 0.1 mm	
Internal Cycle Time:	2 ms	

Accuracy

Linearity:	50...250 ± 0.1 mm 255...2000 ± 0.04 % F.S. 2005...2500 ± 0.08 mm
Hysteresis:	± 0.1 mm
Setpoint Tolerance:	≤ 1 mm

Operating conditions

Assembly orientation:	In any direction
Operating temperature electronics, storage temp.:	-40°C...+105°C
Fluid temperature:	-30°C...+85°C
Dew point, humidity:	90 % rel. humidity, no condensation acc. EN60068-2-30

Pressure

Operating pressure ratings:	Ø 10 mm sensor rod	
	PN: 350 bar	Pressure impulse test acc.
	Pmax: 450 bar	DIN EN ISO 19879

IP rating sensor housing

Sensor housing:	IP67, EN60529
-----------------	---------------

Environmental testing:

Shock:	IEC-68-2-27 100 g (6 ms) single hit 50 g (11 ms) at 1000 Shocks per axis
Vibration:	IEC 68-2-6 (10...2000 Hz) Ø 10 mm sensor rod 15g (r.m.s)
EMC:	ISO 14982 agricultural and forestry machines ISO 11452-2 (radiated immunity) (Increased immunity voltage output 100V/m) ISO 11452-4 (conducted immunity) ISO 7637-1/2 (transient Impulses)

Materials and dimensions

Sensor rod:	Stainless steel 1.4306 / AISI 304L (Ø 10 mm)
Housing:	Stainless steel 1.4305 / AISI 303
Mechanical assembly:	Flange housing Ø 48 mm O-ring 40.87 x 3.53 mm NBR 80, backup ring 42.6 x 48 x 1.4 PTFE

Electrical installation

Connector:	Connector System 2 x M12x1 with O-ring 7 x 1.35 mm NBR 70 Connecting flange brass nickel-plated with O-ring 13 x 1.6 NBR 70
Supply voltage:	12/24 VDC (tolerance range 8 - 32 VDC)
Voltage supply ripple:	< 1 % PP
Power drain:	< 1 W
Electric strength:	500 VDC (DC ground to machine ground)
Over voltage protection (GND - VDC):	+ 36 VDC
Polarity protection (GND - VDC):	up to -36 VDC
Load:	R _L ≥ 10 kΩ mA output R _L ≤ 250 Ω (12 VDC) VDC output R _L ≤ 500 Ω (24 VDC) VDC output

Temposonics MT

Analog Redundant

Temposonics® Connector System M12

MTS presents the innovative Connector System for Temposonics® MH-Series
The Temposonics® Connector System meets the most exacting protection requirements important for the difficult environmental conditions of mobile hydraulics applications. Protection type IP69K makes the robust metal housing not only completely dust- and waterproof, even the harshest cleaning measures can not damage the sensor.

- A** The MH sensor is delivered by MTS together with the new Connector System: The connector insert carrier is already connected to the sensor conductors, i.e. no soldering, any colour or connection mistake.
- B** The connector insert is taken out of the cylinder through a bore hole. The flange housing can be clicked in position easily from outside.

- C** Four standard screws must be tightened to mount the Connector System on the cylinder.
- D** With a corresponding mating plug the Connector System fulfills an IP rating of IP69K.

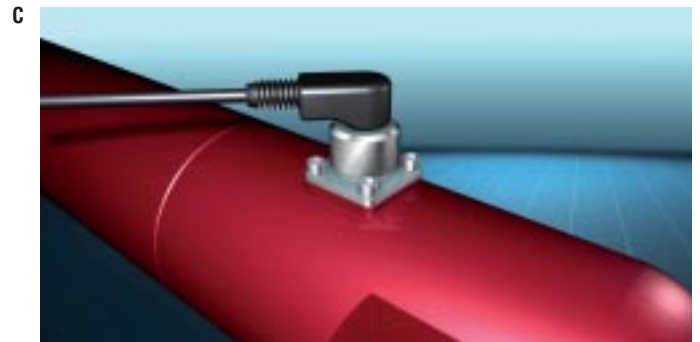
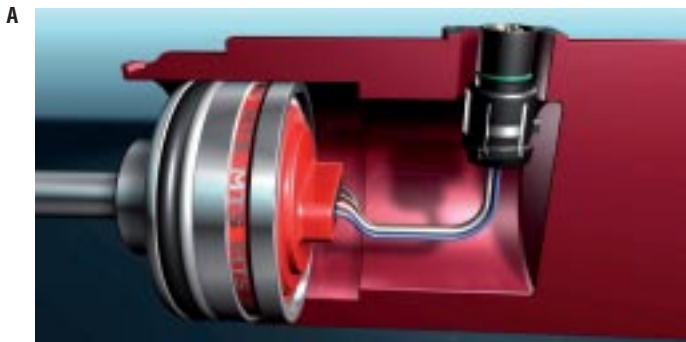

Temposonics MT Redundant Sensor

MH-Series model MT sensors were designed with the mobile world in mind and apply specifically to applications that require redundancy. They help lower overall costs by increasing safety, availability and reliability and reducing service costs. MH-Series sensors are designed specifically for position sensing applications in rugged environments typically encountered by construction, agricultural and other off-highway machinery and have been validated in the field by

customers worldwide. Their performance is second-to-none. Ruggedness is “designed in” along with 100 g shock and 15 g vibration rating. Cable wires are sized for direct connection to industry proven connectors. The model MT can be fully sealed and embedded in a cylinder to ensure a long operation life.

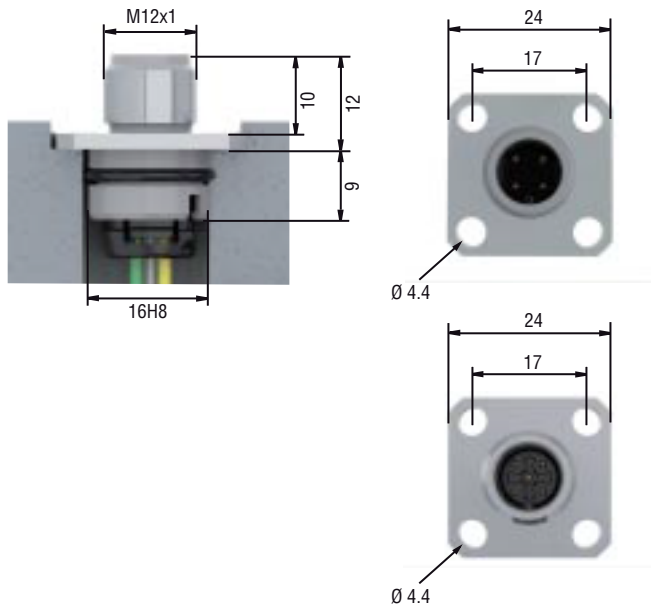
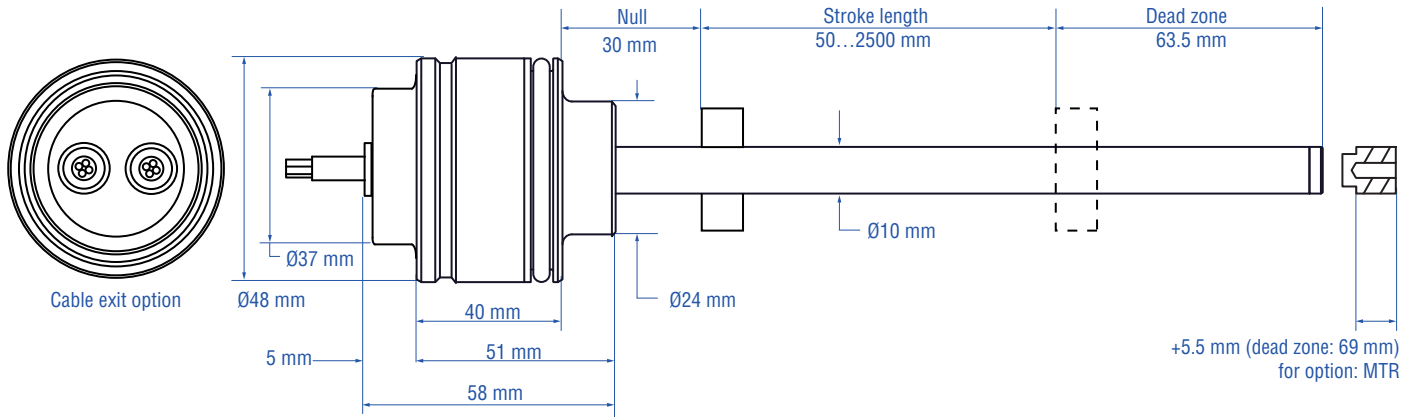

Pin Assignment (e.g. N06R)

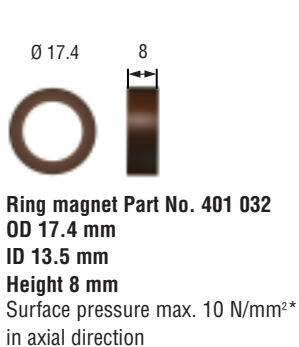
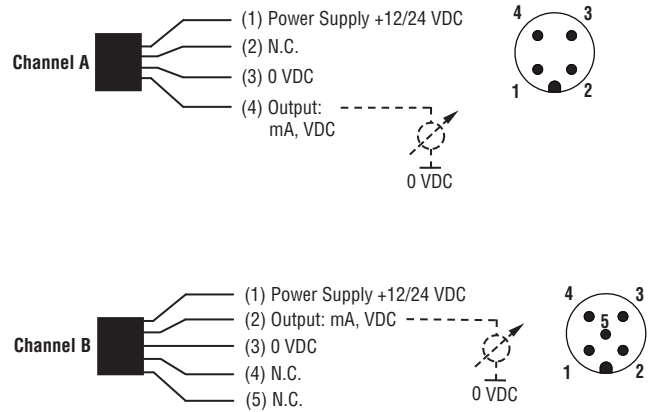

*max. mechanical burden, e.g. by cir-clip, lock washers etc.

Temposonics MT

Analog Redundant

Mechanical Installation

The robust Temposonics® model MT sensor's new stainless-steel housing is designed for direct stroke measurement in hydraulic cylinders. The Temposonics® MT sensor can be installed from the head side or the rod side of the cylinder depending on the cylinder design.

Example

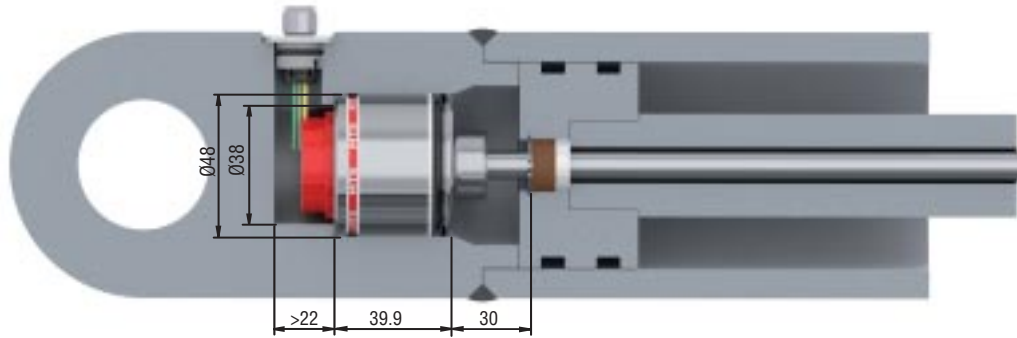

Sensor Installation

The method of installation is entirely dependent on the cylinder design. While the most common method of installation is from the rod side of the cylinder, installation from the head side of the cylinder is also possible. In both installation methods, the cylinder is sealed by O-ring and backup ring which is ready installed on the sensor housing.

Installation Notes

- Use a non-ferrous circlip to fix the magnet.
- The bore in the piston rod is dependent on hydraulic pressure and piston velocity etc. The minimum drilling should be 13.5 mm (10 mm rod).

1. Installation in magnetic Material with Spacer

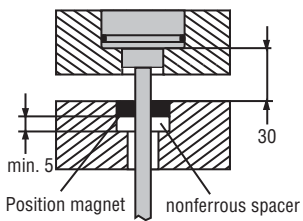

2. Installation in non-magnetic Material without Spacer

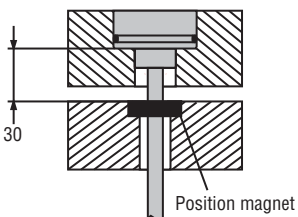

Detail Flange Housing

e.g. retaining with set screw DIN 913
M5x10 (with flat point!)
max. torque 0.5 Nm

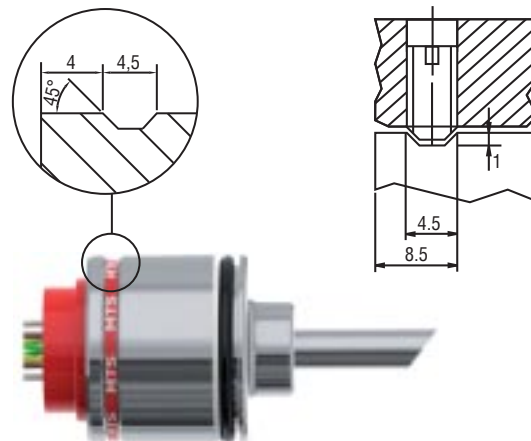

All dimensions in mm.

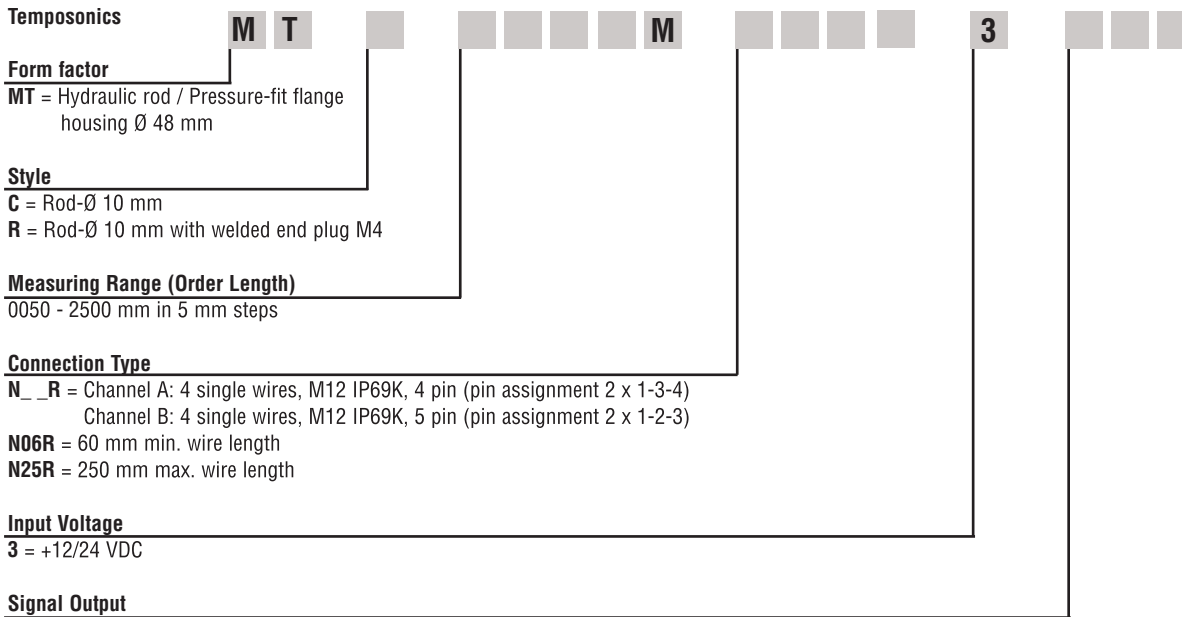

	Channel A	Channel B
V11 =	0.25 - 4.75 VDC	0.25 - 4.75 VDC
V12 =	0.5 - 4.5 VDC	0.5 - 4.5 VDC
A13 =	4.75 - 0.25 VDC	4.75 - 0.25 VDC
A14 =	4.5 - 0.5 VDC	4.5 - 0.5 VDC
V21 =	0.25 - 4.75 VDC	4.75 - 0.25 VDC
V22 =	0.5 - 4.5 VDC	4.5 - 0.5 VDC
A01 =	4 - 20 mA	4 - 20 mA
A04 =	20 - 4 mA	20 - 4 mA
A21 =	4 - 20 mA	20 - 4 mA

Scope of Delivery

Position Sensor, O-Ring, Backup-Ring
Please order magnets separately.

Accessories (selection)	Part No.
Ring magnet OD17.4	401 032
Ring magnet OD25.4	400 533
Ring magnet OD33	201 542-2
MH Testkit	280618

Scope of delivery:

- MH-Series analog / PWM Tester
- 12 VDC battery charger with adapter (adapter main plug EU, adapter main plug UK)
- Cable with M12*1 connector
- Cable with pigtailed wires
- Carrying case
- CD-Rom with user's guide



Document Part Number:
551218 Revision F (EN) 07/2016

LOCATIONS

GERMANY
MTS Sensor Technologie GmbH & Co. KG
Auf dem Schüffel 9
58513 Lüdenscheid, Germany
Tel. + 49 2351 9587-0
Fax + 49 2351 56491
info.de@mtssensors.com
www.mtssensor.de

USA
MTS Systems Corporation Sensors Division
3001 Sheldon Drive
Cary, N.C. 27513, USA
Tel. +1 919 677-0100
Fax +1 919 677-0200
info.us@mtssensors.com
www.mtssensors.com

JAPAN
MTS Sensors Technology Corp.
737 Aihara-machi,
Machida-shi,
Tokyo 194-0211, Japan
Tel. + 81 42 775-3838
Fax + 81 42 775-5512
info.jp@mtssensors.com
www.mtssensor.co.jp

FRANCE
MTS Systems SAS
Zone EUROPARC Bâtiment EXA 16
16/18, rue Eugène Dupuis
94046 Creteil, France
Tel. + 33 1 58 4390-28
Fax + 33 1 58 4390-03
info.fr@mtssensors.com
www.mtssensor.com

ITALY
MTS Systems Srl.Sensor Division
Via Camillo Golgi, 5/7
25064 Gussago (BS), Italy
Tel. + 39 030 988 3819
Fax + 39 030 982 3359
info.it@mtssensors.com
www.mtssensor.com

CHINA
MTS Sensors
Room 504, Huajing Commercial Center,
No. 188, North Qinzhou Road 200233
Shanghai, China
Tel. +86 21 6485 5800
Fax +86 21 6495 6329
info.cn@mtssensors.com
www.mtssensors.cn

LEGAL NOTICES

MTS, Temposonics and Level Plus are registered trademarks of MTS Systems Corporation in the United States; MTS SENSORS and the MTS SENSORS logo are trademarks of MTS Systems Corporation within the United States. These trademarks may be protected in other countries. All other trademarks are the property of their respective owners. Copyright © 2016 MTS Systems Corporation. No license of any intellectual property rights is granted. MTS reserves the right to change the information within this document, change product designs, or withdraw products from availability for purchase without notice. Typographic and graphics errors or omissions are unintentional and subject to correction. Visit www.mtssensors.com for the latest product information.

