

Temposonics®

Magnetostrictive, Absolute, Non-contact
Linear-Position Sensors



R-Series
Rod Model RS

Document Part Number
551251 Revision A

Data Sheet



Model RS Rod-style sensor with IP68/IP69K Super Shield Housing

FEATURES

- Robust Sealed Housing IP68/IP69K
- Analog, SSI, DeviceNet, Profibus, EtherCAT and CANbus Outputs

BENEFITS

- Available for R-Series Rod-Style Sensors
- Rugged Industrial Sensor
- Linear, Absolute Measurement
- Non-Contact Sensing Technology

APPLICATIONS

- Ideal For Hydraulic and Pneumatic Cylinders in Wash Down Environments
- Continuous Operation In Harsh Industrial Conditions
- Additional Protection for Exposed Outdoor Environments

TYPICAL INDUSTRIES

- Fluid Power
- Material Handling and Packaging
- Valve and Gate Positioning

Time-based Magnetostrictive position sensing principle

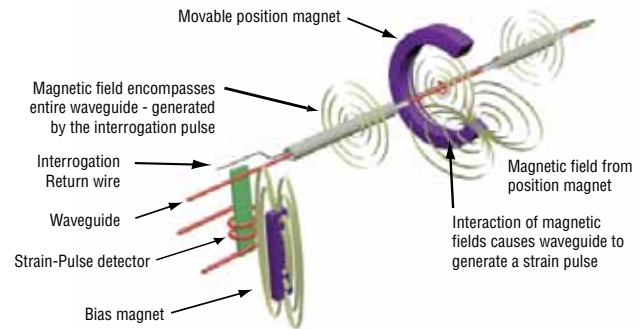

Benefits of Magnetostriction

Temposonics linear-position sensors use the time-based magnetostrictive position sensing principle developed by MTS. Within the sensing element, a sonic-strain pulse is induced in a specially designed magnetostrictive waveguide by the momentary interaction of two magnetic fields. One field comes from a moveable permanent magnet that passes along the outside of the sensor. The other field comes from an “interrogation” current pulse applied along the waveguide. The resulting strain pulse travels at sonic speed along the waveguide and is detected at the head of the sensing element.

The position of the magnet is determined with high precision and speed by accurately measuring the elapsed time between the application of the interrogation pulse and the arrival of the resulting strain pulse with a high-speed counter. The elapsed time measurement is directly proportional to the position of the permanent magnet and is an absolute value. Therefore, the sensor’s output signal corresponds to absolute position, instead of incremental, and never requires recalibration or re-homing after a power loss. Absolute, non-contact sensing eliminates wear, and guarantees the best durability and output repeatability.

All specifications are subject to change. Contact MTS for specifications and engineering drawings that are critical to your application. Drawings contained in this document are for reference only. Go to <http://www.mtssensors.com> for the latest support documentation and related media.

Product Overview and Specifications

Product overview

The extremely robust Temposonics® Rod-style Model RS sensor with super shield housing ensures long-term linear position measurement in the harshest environments. Hermetically sealed with a housing completely made of stainless steel, it meets protection modes IP68 and IP69K requirements and are reliably shielded against corrosion and penetration of dirt and water.

Due to non-contact measuring technology, sensor integration into a hermetically sealed housing is possible. A position magnet moves along the outside of the pressure-resistant sensor pipe and marks the position without mechanical contact.

For level measurement, an optional float can be used. The modular sensor cartridge design enables the customer to choose the specific sensor output configurations to be installed within the super shield housing to best fit their application requirements. The measuring accuracy and all technical data correspond to the features of the sensor selected inside the housing.

A wide choice of interfaces (Analog, Profibus, SSI, CANbus, DeviceNet, and EtherCAT) is available. Moreover, integration of ATEX-certified and intrinsically safe sensors is possible with the protective housing. For specific information, refer to the specific R-Series sensor data sheet.

Temposonics® Model RS sensors are made to fit Temposonics® R-Series with analog and digital outputs. Fixed cable and connector versions can be used on the sensor side. When using standard sensors in this housing, you get a cost efficient solution for use in rugged applications. Several design combinations are available to fit your application: M18 or 3/4" UNF mounting flange thread, various housing lengths, and single, dual or triple cable glands.

Serial communication and a simple PC-based user interface enable remote sensor programmability and diagnostics without the need to compromise the housing's protection rating. These features can be used to simplify machine design, sensor setup and field programming.

Product specifications

Consult the individual R-series sensor data sheet for product specifications and ordering information at www.mtssensors.com

Parameters	Specifications
OUTPUT	
Outputs:	Analog, SSI, Profibus, EtherCAT, CANbus, and DeviceNet
Stroke length:	Range (Rod style): 50 mm to 7620 mm (2 in. to 300 in.)
ENVIRONMENTAL	
Operating conditions:	Operating temperature: -40 °C (-40 °F) to +75 °C (+167 °F) Relative humidity: 100% Sealing: IP68/IP69K
EMC test:	Electromagnetic emission: IEC/EN 50081-1 Electromagnetic susceptibility: IEC/EN 50082-2, IEC/EN 61000-4-2/3/4/6, level 3/4 criterium A, CE qualified
Shock rating:	100 g (single hit)/IEC standard 68-2-27 (survivability)
Vibration rating:	15 g / 10 to 2000 Hz / IEC standard 68-2-6
FORM FACTOR MATERIAL (MODEL RS)	
Electronic head:	303/304 stainless steel or 304L (1.4404) on request
Sensor rod:	303/304 stainless steel or 304L (1.4305) on request
Operating pressure:	350 bar static, 690 bar peak (5000 psi static, 10,000 psi peak)
Mounting:	Any orientation. Threaded flange M18 x 1.5 or 3/4 - 16 UNF-3A
Typical mounting torque:	45 N-m (33 ft. - lbs.)
Magnet types:	Ring magnet, open-ring magnet, or magnet float

Model RS rod-style sensor dimension reference

The Temposonics R-Series rod-style sensor (Model RS) offers modular construction, flexible mounting configurations, and easy installation. The Model RS sensor is designed for mounting in applications where high pressure conditions exist, (5000 psi continuous, 10,000 psi spike), such as inside hydraulic cylinders. The Model RS sensor may also be mounted externally in many applications.

MODEL RS, ROD-STYLE SENSOR WITH IP68/IP69K HOUSING

Drawing is for reference only, contact applications engineering for tolerance specific information.

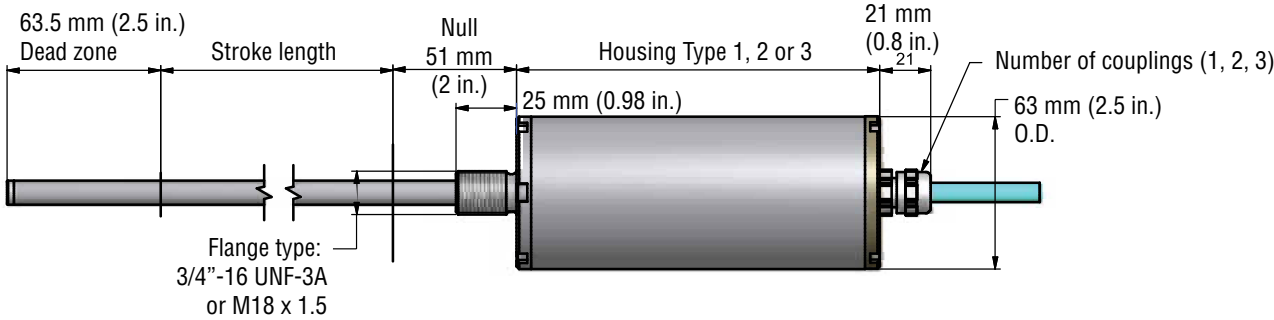

Figure 1. Model RS Rod-style sensor dimension reference. (See Figures 5, 6 and 7 for cable gland exits)

MODEL RS, ROD-STYLE SENSOR WITH TYPE 1 HOUSING

Drawing is for reference only, contact applications engineering for tolerance specific information.

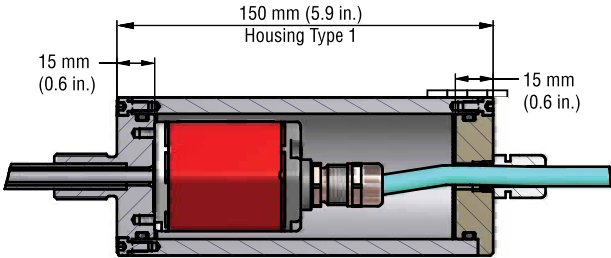

Figure 2. Model RS Rod-style sensor dimension reference (shown with *Type 1* housing)

MODEL RS, ROD-STYLE SENSOR WITH TYPE 2 HOUSING

Drawing is for reference only, contact applications engineering for tolerance specific information.

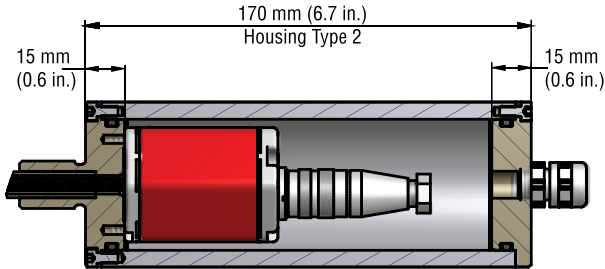

Figure 3. Model RS Rod-style sensor dimension reference (shown with *Type 2* housing)

MODEL RS, ROD-STYLE SENSOR WITH TYPE 3 HOUSING

Drawing is for reference only, contact applications engineering for tolerance specific information.

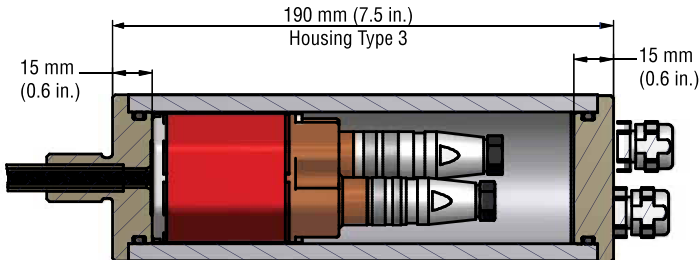

Figure 4. Model RS Rod-style sensor dimension reference (shown with *Type 3* housing)

Model RS Rod-Style Sensor Cable Gland Exits

Single, dual or triple cable glands are required for your specific R-Series Rod-style sensor selection (as shown in Figures 5, 6 and 7). Consult the R-Series Sensor Data Sheet for specific connection, wiring and mounting information.

MODEL RS, ROD-STYLE SENSOR CABLE GLAND EXITS

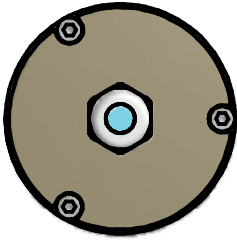

Figure 5. Model RS Rod-style sensor (shown with *Single* cable gland exit)

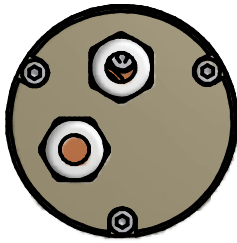

Figure 6. Model RS Rod-style sensor (shown with *Dual* cable gland exit)

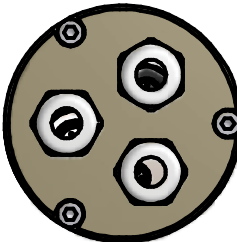

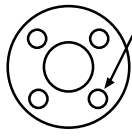

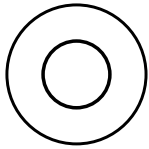

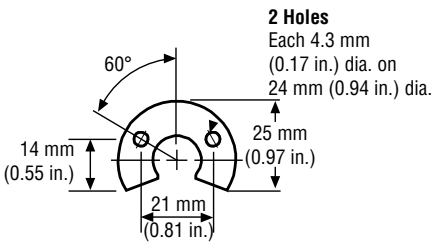

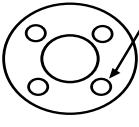

Figure 7. Model RS Rod-style sensor (shown with *Triple* cable gland exit)

Standard magnet selections (Model RS)

Magnets must be ordered separately with Model RS position sensors. The standard ring magnet (part number 201542-2) is suitable for most applications.

POSITION MAGNET SELECTIONS (Magnet must be ordered separately) (Drawing dimensions are for reference only)

Magnet and magnet dimensions	Description	Part number
  <p>4 Holes Each 4.3 mm (0.17 in.) dia. 90° apart on 24 mm (0.94 in.) dia.</p>	<p>Standard ring magnet I.D.: 13.5 mm (0.53 in.) O.D.: 33 mm (1.3 in.) Thickness: 8 mm (0.3 in.) Operating temperature: - 40 °C to 100 °C</p>	201542-2
 	<p>Ring magnet I.D.: 13.5 mm (0.53 in.) O.D.: 25.4 mm (1 in.) Thickness: 8 mm (0.3 in.) Operating temperature: - 40 °C to 100 °C</p>	400533
  <p>2 Holes Each 4.3 mm (0.17 in.) dia. on 24 mm (0.94 in.) dia.</p>	<p>Open-ring magnet, Style M I.D.: 13.5 mm (0.53 in.) O.D.: 33 mm (1.3 in.) Thickness: 8 mm (0.3 in.) Operating temperature: - 40 °C to 100 °C</p> <p>This magnet may influence the sensor performance specifications for some applications.</p>	251416-2
  <p>4 Holes Each 4.3 mm (0.17 in.) dia. 90° apart on 24 mm (0.94 in.) dia.</p>	<p>Magnet spacer (Non-ferrous, use with ring magnet Order number: 201542-2) I.D.: 14 mm (0.56 in.) O.D.: 32 mm (1.25 in.) Thickness: 3.2 mm (0.125 in.)</p>	400633

MAGNET FLOAT SELECTION (Drawing dimensions are for reference only)

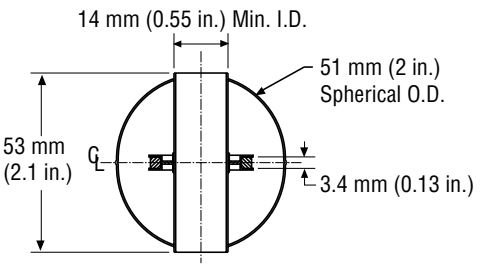
  <p>14 mm (0.55 in.) Min. I.D. 51 mm (2 in.) Spherical O.D. 53 mm (2.1 in.) 3.4 mm (0.13 in.)</p>	<p>Magnet float (Level sensing applications) Specific gravity: 0.70 maximum Pressure: 870 psi maximum</p> <p>(This float is used with the Model RS Rod-style sensors for hydraulic fluid or fresh water applications only)</p>	251447
--	---	--------

Models RS Sensors Ordering Information

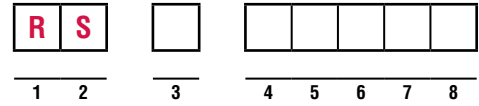

SENSOR MODEL _____ = R S **1-2**

RS = Rod style sensor with Super Shield Housing

PRESSURE PIPE FLANGE _____ = **3**

M = Flange M18 x 1.5 **S** = Flange 3/4 in. -16 UNF - 3A

STROKE LENGTH _____ = **4-8**

____ **M** = Millimeters
(Encode in 5 mm increments)

____ **U** = Inches and tenths
(Encode in 0.1 in. increments)

Stroke Length Notes:

Rod-style sensor (model RS) stroke range = 50 mm (2 in.) - 7620 mm (300 in.)

SENSOR PARAMETERS

Refer to the individual R-Series data sheet **to complete the order number beyond position '8'** for outputs: Analog, SSI, CANbus, DeviceNet, Profibus and EtherCAT.



Document Part Number: 551251, Revision A 10/11

MTS and Temposonics are registered trademarks of MTS Systems Corporation.
All other trademarks are the property of their respective owners.

Printed in USA. Copyright © 2011 MTS Systems Corporation. All Rights Reserved in all media.



**MTS Systems Corporation
Sensors Division**

3001 Sheldon Drive
Cary, North Carolina
27513, USA
Tel.: +1-800-633-7609
Fax: +1-919-677-2343
+1-800-498-4442
e-mail: sensorsinfo@mts.com
<http://www.mtssensors.com>

**MTS Sensor Technologie
GmbH & Co. KG**

Auf dem Schüffel 9
D - 58513 Lüdenscheid, Germany
Tel.: +49-2351-9587-0
Fax: +49-2351-56491
e-mail: info@mtssensor.de
<http://www.mtssensor.de>

**MTS Sensors Technology
Corporation**

737 Aihara-cho, Machida-shi
Tokyo 194-0211, Japan
Tel.: +81-42-775-3838
Fax: +81-42-775-5516
e-mail: info@mtssensor.co.jp
<http://www.mtssensor.co.jp>