

# Temposonics®

Magnetostrictive, Absolute, Non-contact  
Linear-Position Sensors



## C-Series Model CR

Rod-and-Cylinder Sensor

### Product Specification

#### Proven Reliable C-Series Sensors - In A Rugged, Ready-To-Work, Bolt-On Package

##### PRIMARY FEATURES

- Proven Reliable, Magnetostrictive Non-Contact, Absolute Position Sensing Technology
  - Will not wear out, particularly important in “dithering” or vibrating installations
  - No re-calibration needed
- Versatile and Rugged Mechanical Package Allows A Variety Of Simple, Fast Installation Options
  - IP 67 Rated
  - Thick steel housing protects sensor electronics from mechanical damage
  - Rod-and-Cylinder mechanical design enables simple “bolt on” installation
- Cost Optimized
  - Combines low cost C-Series product with mechanical package designed for cost efficiency in production.



##### PRODUCT OVERVIEW

In 2004, the C-Series modular sensor line was created to support OEMs who recognize the benefits of magnetostrictive position sensing technology with an automation-driven sensing solution that had pricing attractive enough even for consumer products.

Due to demand, MTS has packaged this proven magnetostrictive sensing technology for low to moderate volume users and OEM's as an easy, quick to implement, low engineering content bolt-on component.

The newest addition to the Temposonics C-Series product line, the *Model CR Rod-and-Cylinder Sensor*, integrates a standard Model CS or CM sensor inside this new rugged mechanical package enables fast and simple installation of the sensor in a wide variety of applications.

All specifications are subject to change. Contact MTS for specifications and engineering drawings that are critical to your application. Drawings contained in this document are for reference only. Go to <http://www.mtssensors.com> for the latest support documentation and related media.

## Product specifications

Unless otherwise stated, all specifications are typical at 20 °C. All specifications are subject to change. Please contact MTS for specifications that are critical to your needs. Contact MTS for information relevant to seal characteristics. MTS recommends that these sensors be qualified for use in the application intended – Contact MTS applications engineering for specifics. For more information go to [www.mtssensors.com](http://www.mtssensors.com).

### SENSOR ELECTRONICS AND INTERCONNECT

| Parameters                        | Specifications   |
|-----------------------------------|--|
| <b>OUTPUTS</b>                    |  |
| <b>Measured output variables:</b> | Forward acting (voltage increasing)/rod extending  |
| <b>Non-linearity:</b>             | ± 0.3 mm (± 0.012 in.)   |
| <b>Repeatability:</b>             | ± 25 microns   |
| <b>Hysteresis:</b>                | ± 25 microns   |
| <b>Analog Outputs:</b>            | <b>Input voltage choice 1:</b><br>0.1 to 4.9 Vdc at +5 Vdc supply, ratiometric with V supply<br><b>Input voltage choice 2:</b><br>0.1 to 4.9 Vdc, fixed output (internal reference) at +12 Vdc supply, ratiometric at 5 Vdc supply, enhanced EMI protection. |
| <b>PWM</b>                        | Active high at >60% Vs, inactive low at < 30% Vs<br>PWM high period = Waveguide sonic velocity (2702 meters (8863 feet) to 2890 meters (9479 feet)/sec; median 2794 meters (9164 feet) /sec or 0.3579 μsec/mm) x (stroke position).                          |
| <b>Position measurement:</b>      | <b>Stroke range availability:</b><br>72.3 mm, 109.3 mm, 148.0 mm, 186.3 mm, 217.3 mm, and 250.1 mm<br><b>Update rate/times:</b><br>2.6 kHz / 385 microsecond period  |

### ELECTRONICS

|                           |   |
|---------------------------|---|
| <b>Operating voltage:</b> | <b>Input voltage choice 1:</b><br>5 Vdc -5%,+10%<br><b>Input voltage choice 2:</b><br>12 Vdc ± 25% or 5 Vdc -5%, +10% |
| <b>Current drain:</b>     | 40 mA typical   |
| <b>Temperature drift:</b> | ± 20 micron/°C, PWM ± 10 micron/°C  |
| <b>Output load:</b>       | <b>Analog:</b> 6k ≤ R ≤ 10k<br><b>PWM:</b> ≥ 400 Ω  |

### ENVIRONMENTAL

|                              |  |
|------------------------------|--|
| <b>Operating conditions:</b> | <b>Operating temperature:</b><br>-40 °C (-40 °F) to +75 °C (+167 °F) |
| <b>Shock rating:</b>         | 5 g / (Single hit) / IEC standard 68-2-27 (survivability)            |
| <b>Vibration rating:</b>     | 1 g / 10-150 Hz / IEC standard 68-2-6                                |

### WIRING

|                         |   |
|-------------------------|---|
| <b>Connection type:</b> | 1 meter pigtail, three conductors, 24 AWG |
|-------------------------|---|

### MECHANICAL PACKAGING

| Parameters  | Specifications  |
|---|---|
| <b>Sealing:</b>   | IP 67<br>Rod seal limited to stroke rate, contact factory for information specific to your application.   |
| <b>Allowable mechanical stroke rate (to maintain rod seal integrity):</b> | Varies with stroke length, temperature, orientation and frequency. Minimum in any orientation, full stroke, 25 °C is 6 strokes per minute continuously. Examples have been tested with random 10 mm strokes at rates up to 48 per minute for 10,000,000 strokes. It's recommended that high cyclic rate applications be discussed with the factory. |
| <b>Tolerance:</b>   | <b>Electrical Zero and Full Scale:</b><br>± 2 mm (0.060 in.) from 'A' reference<br>(See Figure 2 for 'A' Reference)   |
| <b>Mounting:</b>  | Threaded M10 x 1.5 stud and rod end or MTS accessory swivel studs or ball ends  |

**Model CR Sensor Connection and Construction**

The CR sensor is available in two models, a +5 Vdc and a +12 Vdc supply version. The +5 Vdc version is designed for general purpose applications and the output is ratiometric with the input voltage. The +12 Vdc version has a 0 to 5 volt output and is not ratiometric with the supply voltage. It also has additional protection from over voltage and reverse connection and has additional EMC protection for both emissions and immunity. Optionally, it can also be operated at 5 Vdc, but the output becomes ratiometric. Connection is made using a three-wire, 1 meter pigtail cable with 24 AWG wire. (see 'Connections and wiring' on page 4)

**MODEL CR SENSOR ASSEMBLY OVERVIEW**

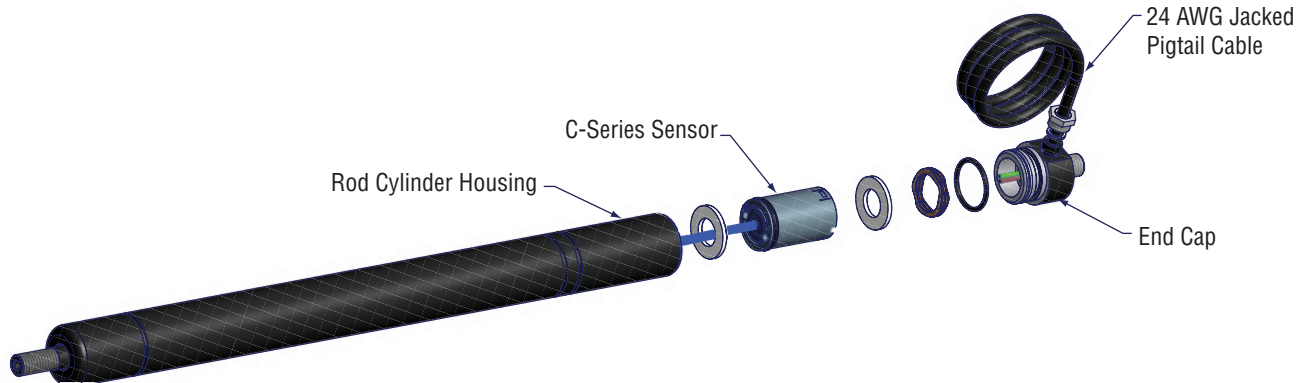

Figure 1. C-Series Model CR sensor assembly reference

**Model CR Sensor dimension references**

**MODEL CR SENSOR (ROD RETRACTED)**

Drawing is for reference only, contact applications engineering for tolerance specific information.

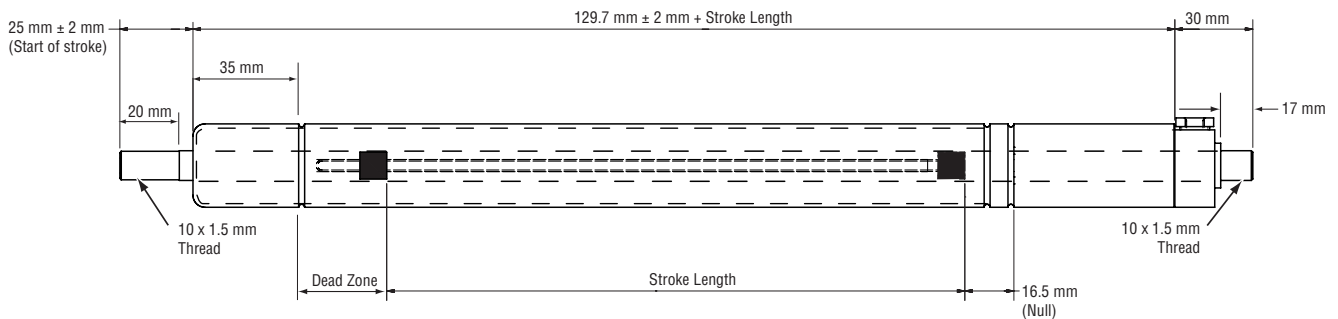

Figure 2. C-Series Model CR sensor dimension reference (rod-in-cylinder)

**MODEL CR SENSOR (ROD EXTENDED)**

Drawing is for reference only, contact applications engineering for tolerance specific information.

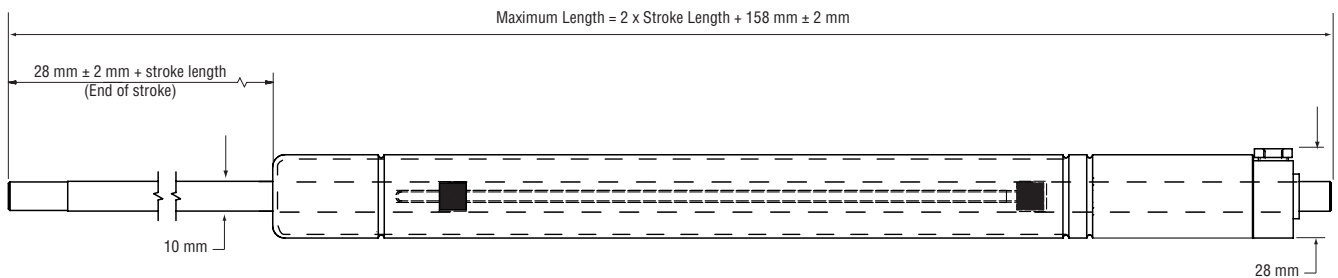

Figure 3. C-Series Model CR sensor dimension reference (Rod fully extended)

## **Model CR Sensor Mounting and Installation**

### **INSTALLATION NOTES & PRECAUTIONS**

The C-Series Model CR is designed to be attached at the threaded rod end and body stud and for the rod to extend and retract linearly. Care should be taken to limit or eliminate both side and axial loads on the piston rod. Excessive mechanical loading will contribute to accelerated seal wear and/or possible mechanical failure of the internal piston during operation.

If the sensor will be exposed to high levels of contamination (dirt, liquids, rocks, dust, chemicals, etc), then additional protection from the environment may be needed to extend the lifetime of the sensor. The two most critical areas for environmental protection are the Rod/Tube seal area and the cable seal.

When the sensor is in use, the back and forth motion of the piston rod can cause wear on the internal seals, and this can be accelerated by the presence of abrasive materials such as dirt or chemicals. If these seals fail, then moisture can enter the primary housing area, and over time, can cause damage to the electronics. (The electronics have a internal secondary seal that will help prevent this, but care should be taken to prevent moisture intrusion).

When mounting the sensor in a vertical orientation, positioning the rod end down can help prevent moisture from working its way past any worn seals.

Cables running to the electronics are also a common path for moisture to access and destroy sensor electronics. The cable/tube interface uses a strain relief seal which provides both mechanical support and a moisture barrier, but again, harsh chemicals and other extreme conditions may require additional protection. Cables that do not have finished connectors at the end (sealed) are susceptible to moisture wicking up between the cable jacket and the conductors, particularly if large temperature changes are encountered (washing/drying cycles, etc). Care should be taken to keep unsealed cable ends out of high moisture environments. This cable is not impregnated and can wick moisture as temperatures rise and fall through both the jacket and the conductor insulation. Care must be taken to properly protect and seal these cable and conductor ends with connectors designed to seal properly.

## **Connections and wiring**

**Note:**

The cable itself is not a sealed type. Therefore, proper cautions must be taken to terminate the pigtail in a manner that does not allow water or other fluids to wick down the wires or insulation.

Connection is made using a three wire, 1 meter pigtail cable with 24 AWG wire. See 'Cable Wire Designations" table for wire colors and functions.

### **CABLE WIRE DESIGNATIONS**

| <b>WIRE COLOR</b> | <b>FUNCTION</b>              |
|-------------------|------------------------------|
| <b>White</b>      | Common                       |
| <b>Green</b>      | Voltage output or PWM output |
| <b>Brown</b>      | Supply voltage (+)           |



**SENSOR MODEL** \_\_\_\_\_ = **C R S** 1 - 3

**CRS** = C-Series Model CR (Rod and Cylinder)

**STROKE LENGTHS** \_\_\_\_\_ = \_\_\_\_\_ 4 - 7

Enter four digit code ( 4 - 7 ) with no decimals as shown below

**0072** = 72.3 mm  
**0109** = 109.3 mm  
**0148** = 148.0 mm  
**0186** = 186.3 mm  
**0217** = 217.3 mm  
**0250** = 250.1 mm

**METRIC** \_\_\_\_\_ = **M** 8

**M** = Metric only

**HOUSING CABLE LENGTH IN METERS** \_\_\_\_\_ = **R 0 1** 9 - 11

**R01** = 1 meter Jacketed cable, pigtail, three conductors, 24 AWG

**INPUT VOLTAGE** \_\_\_\_\_ = \_\_\_\_\_ 12

**1** = 5 volts  
**2** = 12 volts



**OUTPUT** \_\_\_\_\_ = \_\_\_\_\_ 13 - 14

**V0** = Analog voltage  
**P0** = PWM

**Accessory options (Model CR)**

**BALL AND STUD END SELECTIONS (must be ordered separately)**

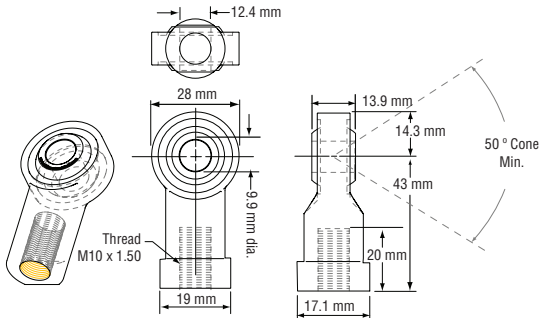
(Drawing dimensions are for reference only)

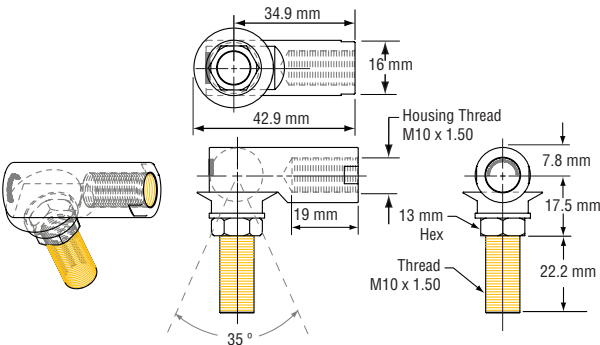
|   | Dimension Reference   | Description               | Part number |
|---|---|---------------------------|-------------|
|  |  | <b>Spherical ball end</b> | 500035      |
|  |  | <b>Spherical stud end</b> | 500036      |



Document Part Number: 551185, Revision A 09-09

MTS and Temposonics are registered trademarks of MTS Systems Corporation.  
All other trademarks are the property of their respective owners.  
All Temposonics sensors are covered by US patent number 5,545,984. Additional patents are pending.  
Printed in USA. Copyright © 2009 MTS Systems Corporation. All Rights Reserved in all media.



**MTS Systems Corporation  
Sensors Division**

3001 Sheldon Drive  
Cary, North Carolina  
27513, USA  
Tel.: +1-800-633-7609  
Fax: +1-919-677-2343  
+1-800-498-4442  
e-mail: [sensorsinfo@mts.com](mailto:sensorsinfo@mts.com)  
<http://www.mtssensors.com>

**MTS Sensor Technologie  
GmbH & Co. KG**

Auf dem Schüffel 9  
D - 58513 Lüdenscheid, Germany  
Tel.: +49-2351-9587-0  
Fax: +49-2351-56491  
e-mail: [info@mtssensor.de](mailto:info@mtssensor.de)  
<http://www.mtssensor.de>

**MTS Sensors Technology  
Corporation**

737 Aihara-cho, Machida-shi  
Tokyo 194-0211, Japan  
Tel.: +81-42-775-3838  
Fax: +81-42-775-5516  
e-mail: [info@mtssensor.co.jp](mailto:info@mtssensor.co.jp)  
<http://www.mtssensor.co.jp>