

Product Specifications



Temposonics LD

Features

- Modular, Non-Contacting Design
- Excellent resolution and repeatability
- Absolute Linear Position Measurement
- Voltage, Current, Start/Stop, and PWM Outputs
- Field-adjustable Zero and Span Settings (analog only)
- CE Certified
- 2-year Warranty

Temposonics LD position sensors utilize a separate electronics housing and interconnection cable to accommodate small spaces. By relocating the electronics, the sensing element head is reduced to minimal size. This makes the Temposonics LD ideal for use with clevis mount cylinders or any space limited cylinder applications.

Like other Temposonics L Series position sensor models, the LD is available with voltage, current, start/stop, and pulse-width-modulated (PWM) output. All outputs are absolute rather than incremental so that power-down situations do not require re-homing.

In addition, Temposonics LD position sensors use non-contacting magnetostrictive technology. Typical industry applications for the L Series position sensors include primary woodworking, plastics processing, hydraulics, and pneumatics.

PARAMETER	SPECIFICATION
Measured Variable:	Displacement
Resolution:	Analog: Infinite* Digital: 1÷ [gradient x crystal freq. (mHz) x circulations]
Non-Linearity**:	± 0.02% or ± 0.10 mm (± 0.004 in.), whichever is greater Minimum absolute linearity varies with sensor model
Repeatability:	Equal to resolution
Hysteresis:	< 0.02 mm (0.0008 in.)
Outputs:	Analog: Voltage or Current Digital: Start/Stop or PWM
Measuring Range:	Analog: 25 to 2540 mm (1 to 100 in.) Digital: 25 to 7620 mm (1 to 300 in.)
Operating Voltage:	+24 Vdc (± 10%)
Power Consumption:	100 mA typical
Operating Temperature:	Head Electronics: - 40 to 85°C (- 40 to 185°F) Sensing Element: - 40 to 105°C (- 40 to 221°F)
EMC Test:	DIN IEC 801-4, Type 4, CE Qualified: DIN EN 50081-1 (Emissions), DIN EN 50082-2 (Immunity)
Shock Rating:	100 g (single hit)/IEC standard 68-2-27 (survivability)
Vibration Rating:	5g/10-150 Hz/IEC standard 68-2-6
Adjustability:	Field adjustable zero and span up to 5% (for Analog sensors only)
Update Time:	Analog: < 1 ms (typical) Digital: Minimum = [Stroke (in inches) + 3] x 9.1 µs
Housing Style/Enclosure:	Sensor Rod with Flange: Stainless Steel Sensing Element Head (at cable entry end): IP 65 Aluminum Die-cast Electronics Housing: IP 65
Operating Pressure:	350 bar static, 690 bar spike (5000 psi static, 10,000 psi spike) pressure rod only
Interconnecting Cable:	9.5 in.
Magnet Type:	Ring or floating magnet



All specifications are subject to change. Please contact MTS for specifications critical to your needs.

\* The above specifications are assuming that output ripple is averaged by the measuring device as with any typical analog device.

\*\* Non-linearity increases with multiple circulations.

Refer to **Installation Guide, Part No. 550653** for additional information, ([www.mtssensors.com](http://www.mtssensors.com)).

## DIGITAL OUTPUTS

The Temposonics L Series position sensors provide direct Start/Stop and PWM outputs. Standard resolution is 0.004 inches (when using a 28 MHz counter). Higher resolutions are possible with increased circulations or with the use of higher resolution counters. Since the outputs are direct, no signal-conditioning electronics are needed when interfacing with controllers or meters.

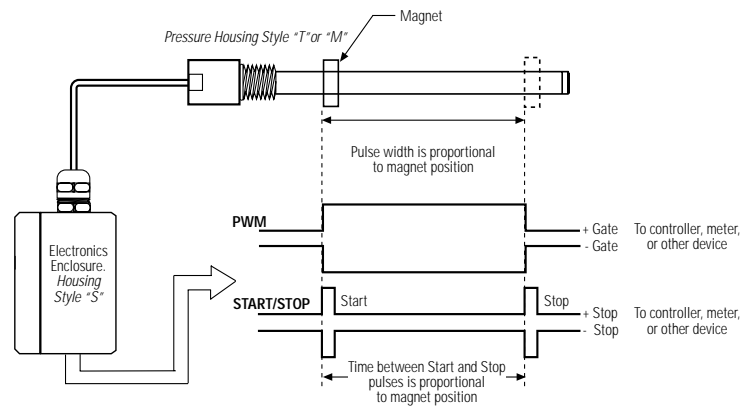

### FEATURES

- Start/Stop or PWM outputs
- High Resolution
- Direct Outputs—No Signal-conditioning Required

## ANALOG OUTPUTS

The Temposonics L Series position sensors provide direct analog outputs, including voltage (0 to 10 Vdc, forward or reverse acting) and current (4 to 20 mA, or 0 to 20 mA, forward or reverse acting). Both voltage and current outputs allow 5% adjustments of zero and span setpoints. Resolution is limited only by the output ripple. Since the outputs are direct, no signal-conditioning electronics are needed when interfacing with controllers or meters.

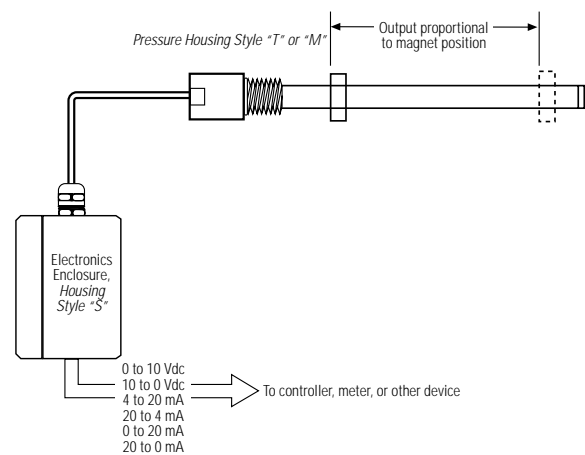

### FEATURES

- Voltage or Current Outputs
- 5% Adjustment on Zero and Span
- Direct Outputs—No Signal-conditioning Required
- High Resolution

# DIMENSIONS

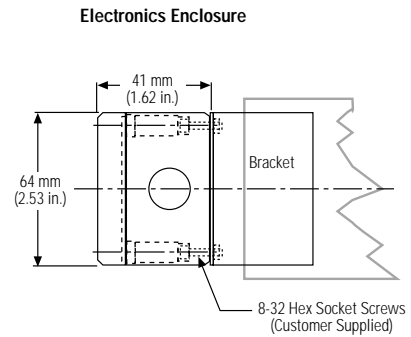
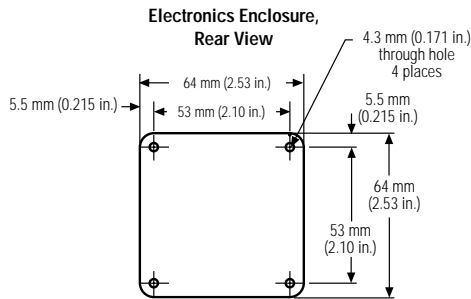
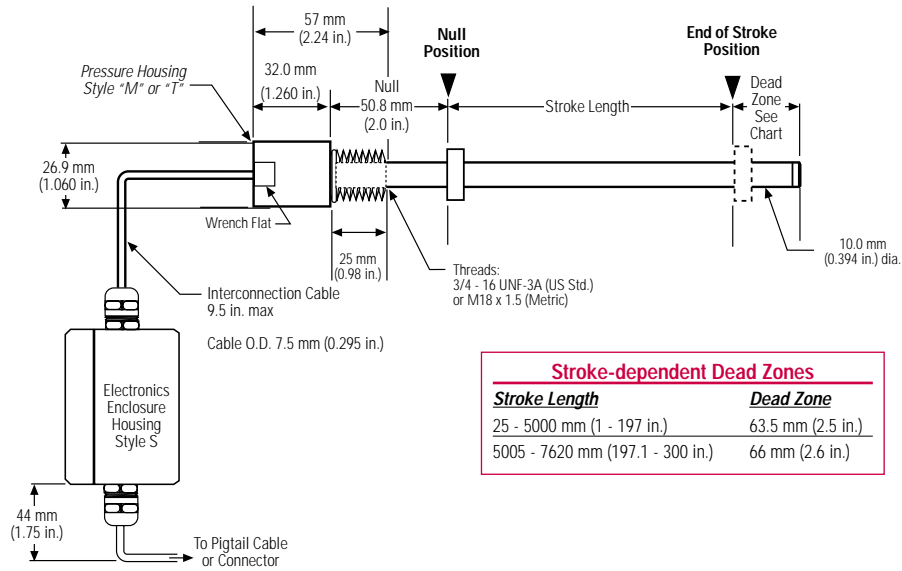

## CYLINDER INSTALLATION

The Temposonics LD position sensors are designed for installation into hydraulic cylinders. The sensor's high-pressure, stainless steel tube installs into a 1/2 inch bore in the piston head and rod assembly as illustrated (right).

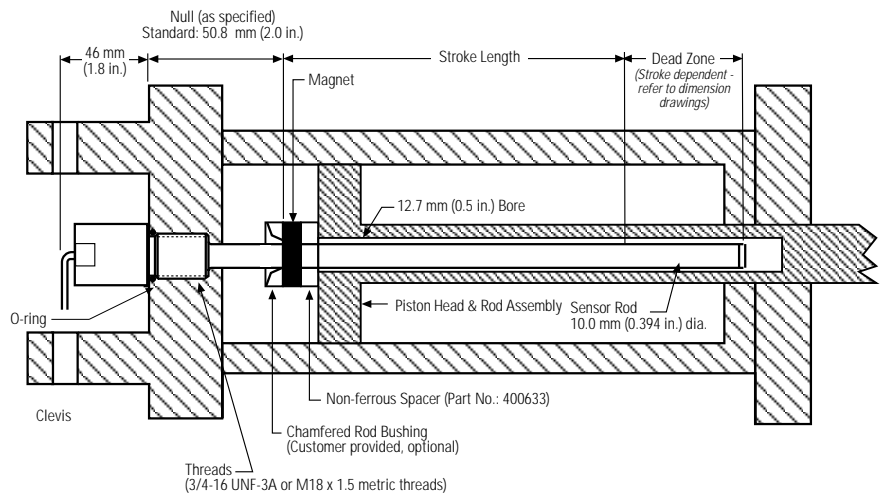

The illustration above represents a **typical** installation. Some installation requirements may be application specific.

## CONNECTION TYPES:

Integral Connector D6  
 Integral Cable with Hanging D6 Connector  
 Integral Cable with Pigtail Termination

Integral or Hanging Connector  
 (D6 Male)  
 (As Viewed from End of Sensor)

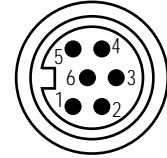

### Analog Output: (Voltage or Current)

Pin No.	Wire Color	Function
1	Gray	0 to 10 Vdc, 4 to 20 mA, 0 to 20 mA
2	Pink	Return for Pin 1
3	Yellow	10 to 0 Vdc, 20 to 4 mA, or 20 to 0 mA
4	Green	Return for Pin 3
5	Red or Brown	Customer Supplied Power (+ 24 Vdc)
6	White	DC Ground

### Digital Output: (PWM or Start/Stop)

Pin No.	Wire Color	Function
1	Gray	(-) Gate for PWM, (-) Stop for Start/Stop
2	Pink	(+) Gate for PWM, (+) Stop for Start/Stop
3	Yellow	(+) Interrogation for PWM, (+) Start for Start/Stop
4	Green	(-) Interrogation for PWM, (-) Start for Start/Stop
5	Red or Brown	Customer Supplied Power (+ 24 Vdc)
6	White	DC Ground

## CONNECTION TYPE:

Integral Cable with Hanging MS Connector

Hanging Connector  
 (MS Male)

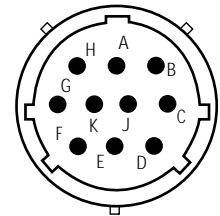

### Analog Output: (Voltage or Current)

Pin No.	Wire Color	Function
A	White	DC Ground
B	Drain	Case Ground
C	Gray	Return for Pin D
D	Pink	0 to 10 Vdc, 4 to 20 mA, or 0 to 20 mA
E	Red or Brown	Customer Supplied Power (+ 24 Vdc)
F	-	No Connection
G	Yellow	10 to 0 Vdc, 20 to 4 mA, or 20 to 0 mA
H	Green	Return for Pin G
J	-	No Connection
K	-	No Connection

### Digital Output: (PWM or Start/Stop)

Pin No.	Wire Color	Function
A	White	DC Ground
B	Drain	Case Ground
C	Gray	(-) Gate for PWM, (-) Stop for Start/Stop
D	Pink	(+) Gate for PWM, (+) Stop for Start/Stop
E	Red or Brown	Customer Supplied Power (+ 24 Vdc)
F	-	No Connection
G	-	No Connection
H	-	No Connection
J	Yellow	(+) Interrogation for PWM (+) Start for Start/Stop
K	Green	(-) Interrogation for PWM

## NOTES:

1) Appropriate grounding of cable shield is required at the controller end.

### For Analog Output:

- When using current (mA) outputs, only one output signal is provided (as selected in the ordering guide). With voltage outputs, both 0 to 10 Vdc and 10 to 0 Vdc output signals are provided.
- Minimum load impedance for voltage outputs is 5K  $\Omega$ .
- Maximum load impedance for current output is 500  $\Omega$ . (Reference to Ground Only, see page 6)

### For Digital Output:

- For single-ended interrogation, the unused interrogation lead must be connected to DC ground at the controller.
- When using PWM with internal interrogation, both interrogation leads must be connected to DC ground.

## CABLE CONNECTORS (Field-installable D6 Female): Mates with Sensor's Integral or Hanging D6 Connector

**D6 Straight-exit Connector**  
Part No. 560700

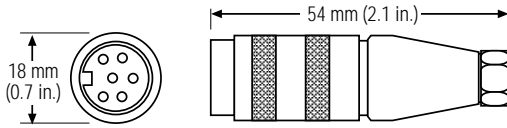

**D6 90° Connector**  
Part No. 560778

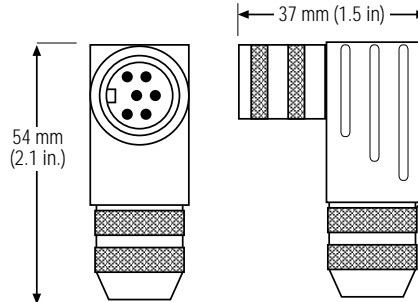

## EXTENSION CABLE WITH CONNECTOR(S) FOR THE D6 CONNECTION TYPE



**SENSOR CONNECTION TYPE**

- D6** = Female connector (straight exit) for sensors with D6 connector
- DA** = Female connector (90° exit) for sensors with D6 connector

**CABLE LENGTHS**

*For standard length cables up to 100 ft.*

- 005** = 5 ft.
- 015** = 15 ft.
- 025** = 25 ft.
- 050** = 50 ft.
- 100** = 100 ft.

*For custom length cables over 100 ft.*

— — — = Cable Length (maximum cable length is dependent on the output selected; consult MTS Applications Engineering.)

**CABLE TERMINATION**

- PO** = Pigtail connection
- D6M** = 6-pin D6 Male connector (straight exit)

## MS CONNECTORS

**Sensor Hanging Connector**  
(MS Male)  
Part No. 370160

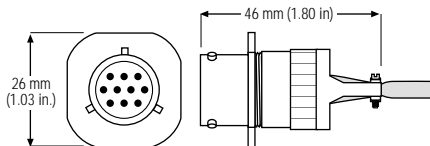

**Cable Connector (Field-installable MS Female)**  
Mates with Sensor Hanging MS Connector  
Part No. 370013

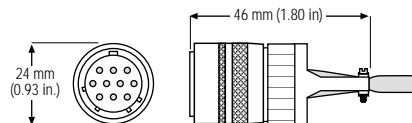

## EXTENSION CABLE WITH CONNECTOR FOR THE MS CONNECTION TYPE

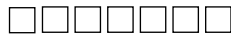

**SENSOR CONNECTION TYPE**

- MS** = Female connector (Part No. 370418) for sensors with MS connector

**CABLE LENGTHS**

— — — = Cable Length (maximum cable length is dependent on the output selected; consult MTS Applications Engineering.)

**CABLE TERMINATION**

- PO** = Pigtail connection

**NOTES:**

- 1) The MS extension cable is usable for either analog or digital outputs. Inside the electronics enclosure, the pins G and J are connected together, and pins H and K are connected together.
- 2) The environmentally sealed MS connector, Part No. 370418, is used on the MS extension cable. It is not field-installable.

## TYPICAL WIRING FOR CURRENT OUTPUT (4-20 mA Loop)

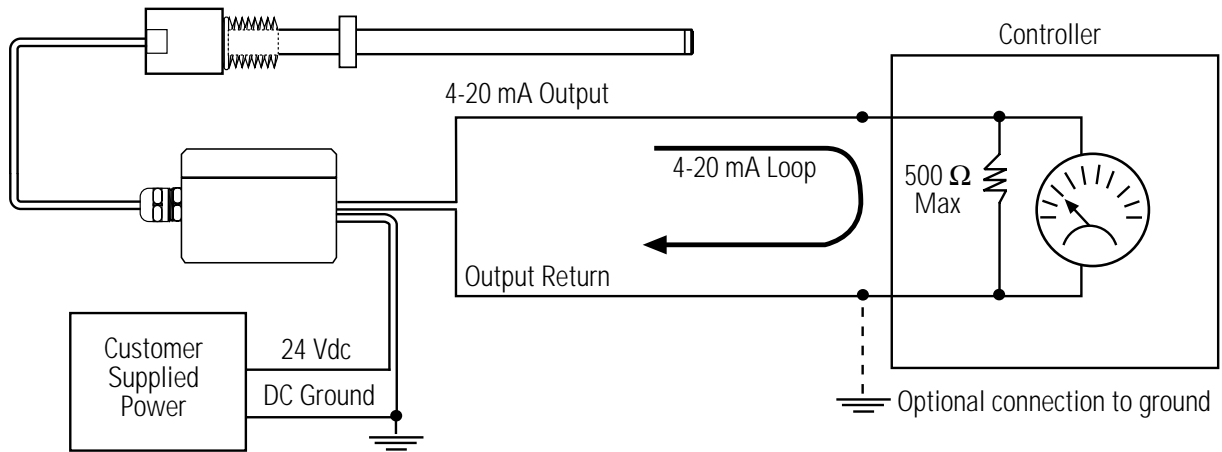

### NOTES:

- 1) Sensor requires connection to customer supplied power and can not be loop-powered from controller.
- 2) The 4-20 mA current loop is powered only by the sensor.
- 3) The sensor's Output Return connection is referenced to DC Ground, (connected internally). To avoid output errors the optional connection to ground at the controller must be at the same potential as DC Ground.

## TERMINAL BLOCK CONNECTIONS INSIDE THE ELECTRONICS HOUSING USED FOR THE SENSING ELEMENT

	Pin No.	Wire Color	Function
See Note 1	TB1-1	Factory Wired	
	TB1-2	Factory Wired	
	TB1-3	Factory Wired	
	TB1-4	Factory Wired	
	TB1-5	Factory Wired	
	TB1-6	Factory Wired	
Sensing element wiring to terminal block. See Note 2	TB1-7	-	No Connection
	TB1-8	-	No Connection
	TB1-9	Customer Connection (Red)	+ 5 V
	TB1-10	Customer Connection (Yellow)	SE Out
	TB1-11	Customer Connection (Black)	Ground
	TB1-12	Customer Connection (Green)	WG -
	TB1-13	Customer Connection (Blue)	WG +

TB1 locations in a Temposcis LD Electronics Housing (view shown with cover removed)

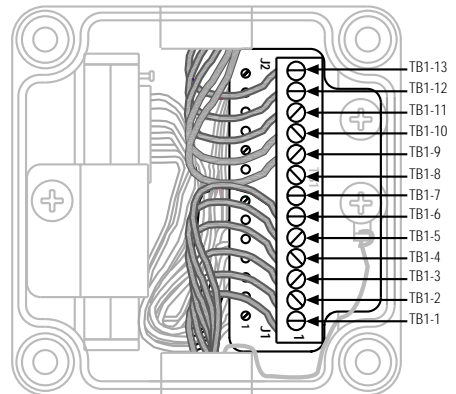

### NOTES:

- 1) TB1-1 through TB1-6 is connected to the internal cable by the factory. Various wire connections are used for the different sensor output styles and connection types.
- 2) Sensors may not be returned for credit if interconnect cable length has been modified.

### CAUTION!

Electronics enclosure and sensing element located in the pressure pipe are a matched set calibrated by the factory. It is important to keep these as matched sets or performance may be affected.



## ACCESSORIES

Description	Part No.	Notes
Magnet Spacer	400633	For use with standard ring magnet 201542
Magnet Mounting Screws	560357	Used to mount standard ring magnet Part No. 201542 (4 screws required)
Power Supply (24/28 Vdc, 0.5 A)	380009	Open frame style
LD O-ring (spare)	560705	For sealing LD pressure tube in the cylinder (black)
Collar	560777	For Temposonics LD sensors with float magnet
Cable	530026	Specify length in feet at time of order
D6 Straight-exit Connector	560700	See drawing on page 5
D6 90° Connector	560778	See drawing on page 5
Sensor MS Hanging Connector	370160	See drawing on page 5
MS Field-installable Connector	370013	See drawing on page 5

### MAGNETS/FLOAT:

Magnets and floats must be ordered separately with Temposonics LD sensors. A variety of magnet styles (right) are available to meet your particular application demands. The standard ring magnet (Part No. 201542) is suitable for most applications .

**Floating Magnet  
Part No. 251416**

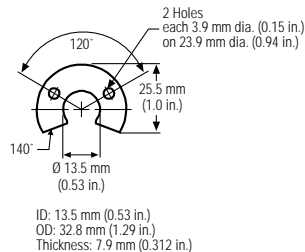

**Standard Ring Magnet  
Part No. 201542**

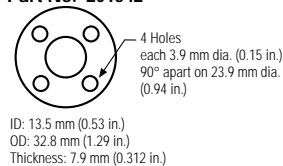

**Ring Magnet  
Part No. 400533**

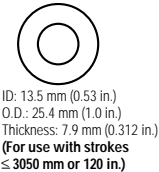

**Ring Magnet  
Part No. 401032**

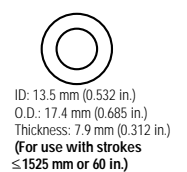

**Float Magnet  
Part No. 251447**

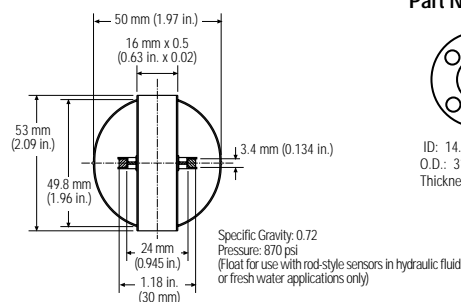

**Magnet Spacer  
Part No. 400633**

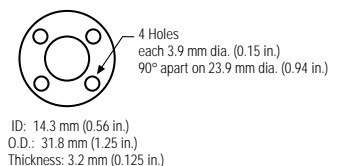

**SENSORS**  
GROUP

Pioneers,  
Innovators,  
Leaders in  
Magnetostrictive  
Sensing

**UNITED STATES**  
MTS Systems Corporation  
Sensors Division  
3001 Sheldon Drive  
Cary, NC 27513  
Tel: 800.633.7609  
Fax: 919.677.0200  
Web: www.mtssensors.com  
Email:  
displacement@mtssensors.com

**GERMANY**  
MTS Systems Corporation  
Sensors Technologie  
Auf dem Schuffel 9, D-58513 Lüdenscheid, Germany  
Postfach 8130 D-58489 Lüdenscheid, Germany  
Tel: + 49.2351.95870  
Fax: + 49.2351.56491  
Web: www.mtssensor.de

**JAPAN**  
MTS Systems Corporation  
Sensors Technologie Japan  
Ushikubo Bldg.  
737 Aihara-cho, Machida-shi  
Tokyo 194-0211, Japan  
Tel: + 81 (42) 775.3838  
Fax: + 81 (42) 775.5512

