



**T e m p o s o n i c s** ®  
*P o s i t i o n S e n s o r s*

**MK292 Digital Output Module**  
*Users Manual*

## GENERAL INFORMATION

### *Phone/Fax Numbers*

---

**Phone:** 919-677-0100

800-633-7609

**Fax:** 919-677-0200

### *Shipping Address*

---

#### **MTS SYSTEMS CORPORATION**

Sensors Division

3001 Sheldon Drive

Cary, North Carolina 27513

### *Office Hours*

---

**Mon. - Thurs.:** 7:30 a.m. to 6:30 p.m. EST

**Friday:** 7:30 a.m. to 5:00 p.m. EST

### *Technical Support (24-Hr.)*

---

**Call:** 800-633-7609 (after hours, press 5)

## Table of Contents

<i>Section</i>		<i>Page</i>
<b>1</b>	<b>INTRODUCTION</b>	<b>1</b>
1.1	System Configuration	2
<b>2</b>	<b>SPECIFICATIONS</b>	<b>3</b>
2.1	MK292 Specifications	3
2.2	Temposonics Position Sensor Specifications	4
<b>3</b>	<b>SYSTEM COMPONENTS</b>	<b>5</b>
3.1	MK292-Compatible Temposonics Position Sensors	5
3.1.1	Temposonics Position Sensor with Start/Stop Output	5
3.1.2	Temposonics Position Sensor with Pulse Width Modulated Output	5
3.1.3	Temposonics Position Sensor with Synchronous Operation	5
<b>4</b>	<b>CONNECTIONS</b>	<b>6</b>
4.1.1	Temposonics II Position Sensors with DPM or RPM	6
4.1.2	SE-based Temposonics LP Position Sensors with Start/Stop Output	6
4.1.3	Temposonics L Series Position Sensors with Start/Stop Output	7
4.2	System Connections	9
4.3	Functional Inputs/Outputs	10
4.3.1	Error Output (Loss of Feedback)	10
4.3.2	Data-Ready Output (Latch Pulse)	10
4.3.3	Data-Hold Input (Latch Inhibit)	11
4.3.4	External Start Input	11
4.3.5	Master/Slave Input	11
<b>5</b>	<b>SYSTEM PARAMETERS</b>	<b>12</b>
<b>6</b>	<b>SHORT FORM PROGRAMMING PROCEDURE</b>	<b>14</b>
<b>7</b>	<b>DETAILED PROGRAMMING PROCEDURE</b>	<b>15</b>
7.1	(RUN) Programming Mode	15
7.2	(REC) Pulse Duration	15
7.3	(SC) Scale Factor	17
7.4	(RE) Resolution	18
7.5	(MR) Measuring Range	19
7.6	(ZERO) Null Adjust	20
7.7	(ZERO) Offset	20
7.8	(RUN) Operation Mode	22
<b>8</b>	<b>OPTIONAL ANALOG OUTPUT FOR THE MK292</b>	<b>23</b>
8.1	Operation Mode 1 (Normal)	23
8.2	Operation Mode 2 (Programmable Adjustment)	24



## 1. Introduction to the MK292 Digital Output Module

---

The MK292 Digital Output Module provides an interface between a Temposonics position sensor with a pulse-width modulated or start/stop output and a system controller. A selection of outputs from the MK292 (BCD, binary, or Gray Code) gives this device nearly universal compatibility.

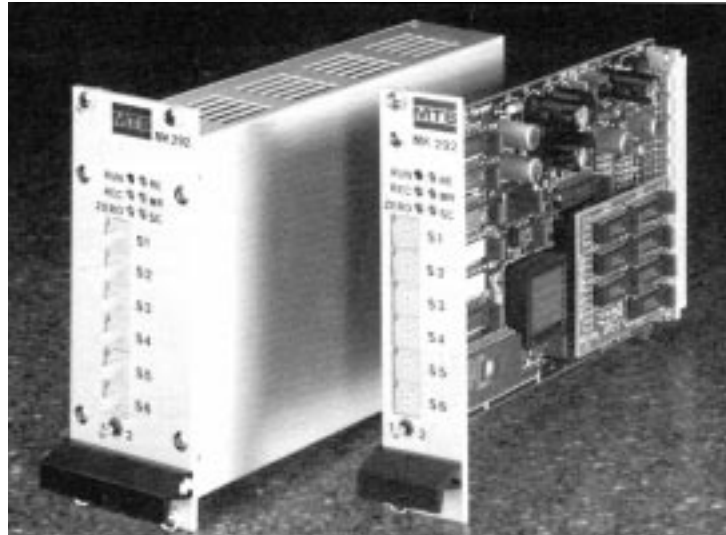
The MK292 is compatible with many Temposonics position sensors, as follows:

Compatible Position Sensors:

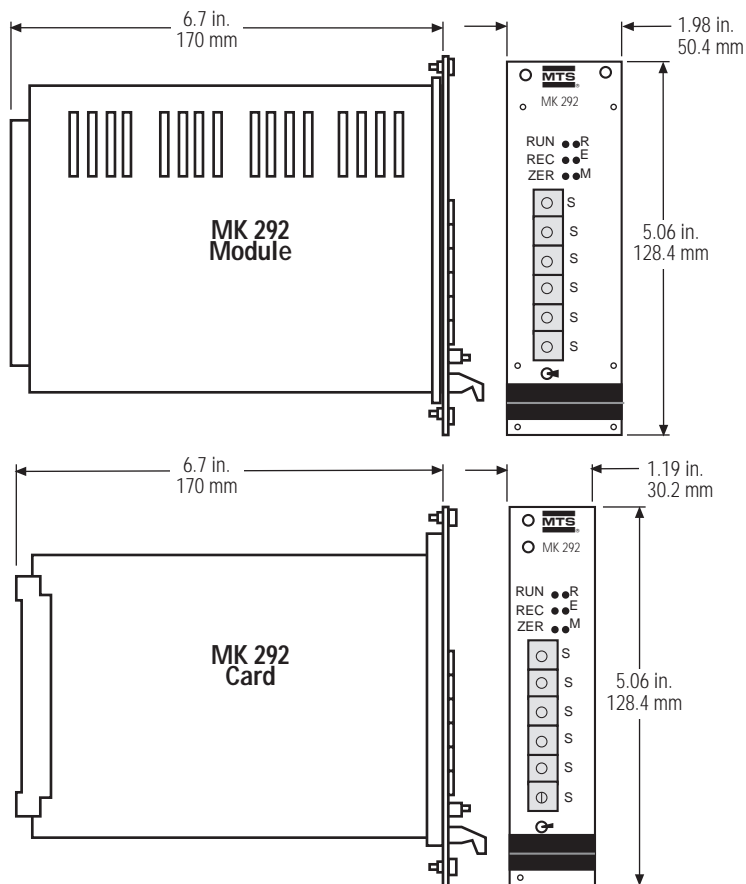
- SE-based Temposonics LP sensor with start/stop output
- Temposonics II sensors with a pulse-width modulated or start/stop output
- Temposonics L Series sensors with a pulse-width modulated or start/stop output

In addition to position data, the MK292 generates logic outputs: DATA READY and ERROR; and logic input: DATA HOLD. An optional sub-board assembly provides an analog output for recording purposes (output range: 0 to 10 Vdc or 10 to 0 Vdc).

The MK292 can be configured as either a rack-mountable card or module that can be installed in a standard 19 inch mounting rack.

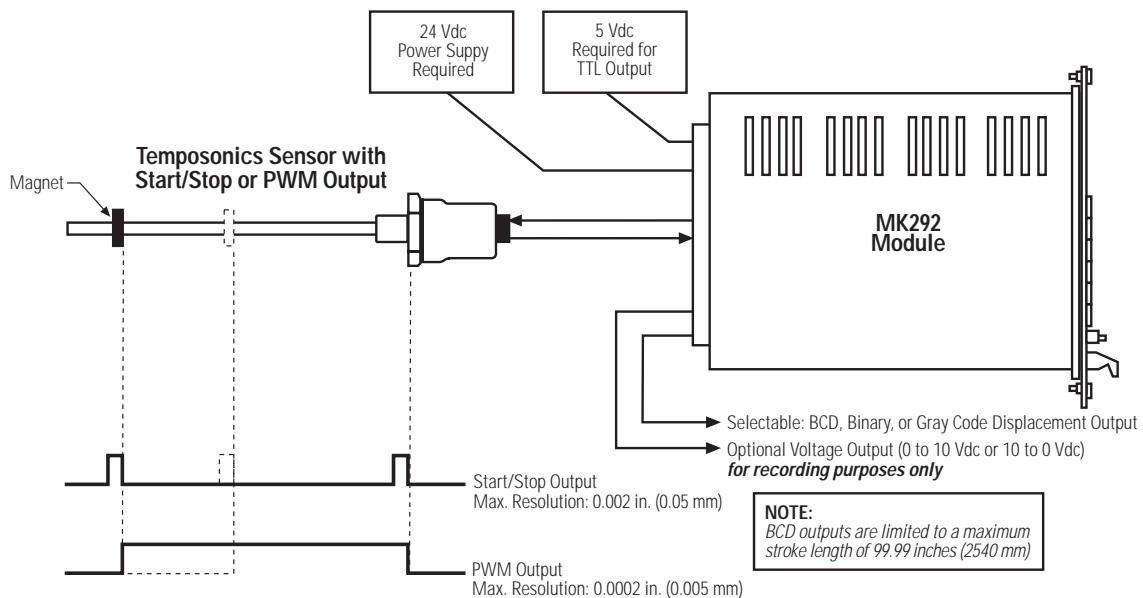


**Figure 1-1**  
**MK292 (Module version, left; card version, right)**



**Figure 1-2**  
**MK292 Digital Output Module Dimensions**

### 1.1 System Configuration



**Figure 1-3**  
**Typical System Configuration**

## 2. Specifications

### 2.1 MK292 Digital Output Module Specifications

<b>Parameter</b>	<b>Specification</b>
Input Voltage:	24 Vdc (-15%/+20%); Ripple: < 5%
	<b>NOTE:</b> <b>An additional 5V power supply is required for the optional TTL level outputs; dual power supply (24/5 Vdc) is available from MTS, P/N 380066</b>
Current Draw:	250 mA maximum
Input Requirement:	SE-based Temposonics LP with start/stop output* Temposonics II with PWM or start/stop output Temposonics L Series with PWM or start/stop output*
Output Format: (Selectable):	Up to 24 bit: <ul style="list-style-type: none"><li>• BCD (<i>maximum stroke length with BCD output scaled in millimeters is 7500 mm. When utilizing inches, strokes may be up to 300 inches</i>)</li><li>• Natural Binary</li><li>• Gray Code</li></ul>
Resolution:	0.002 in. (0.05 mm) with start/stop input 0.0002 in. (0.005 mm) with PWM input
Update Frequency:	Stroke and resolution dependent
Optional Analog (Recorder) Output :	Range: -10 to +10 Vdc ( <i>used for recording; option board required - must be specified upon initial order</i> ) 12 bit resolution 5mv ripple Fully adjustable
Programming Parameters:	Zero Resolution Stroke Length Measuring Direction Analog Output ( <i>used for recording; option board required - must be specified upon initial order</i> )
Operating Temperature:	0 to 60°C (32 to 140°F)
Connection:	64 pin edge connector (DIN 41612; provided with circuit card)
Cable Requirements:	8 x 24 AWG, twisted pairs, shielded low capacitance cable (BELDEN 8105 or equivalent) w/appropriate number of conductors for sensor used
Maximum Cable Length:	Sensor with RS422 output: 500 meters (1640 ft.) Sensor with PWM output: 152.4 meters (500 ft.)
Dimensions:	MK292 Card, Front Panel: 30.2 x 128.4 mm (1.19 x 5.06 in.) MK292 Module, Front Panel: 50.4 x 128.4 mm (1.98 x 5.06 in.)

\* When using the MK292 with a Temposonics LA or LP sensor, please contact Applications Engineering.

Specifications are subject to change without notice. Consult MTS for verification of specifications critical to your application.

## 2.2 Temposonics Position Sensor Specifications

For detailed specifications and installation requirements for the position sensors, refer to the appropriate document, as follows:

- Temposonics II Sensor Installation and Instruction Manual (P/N 550055)
- SE-based Temposonics LP Installation Guide (P/N 550582)
- Temposonics L Series/Digital Product Specification (P/N 550539)

**NOTE (Zero Points):**

*Before ordering an MK292 with a Temposonics LA or LP sensor, consult an MTS Sensors Division Applications Engineer for details regarding the positioning of the sensor's ZERO point.*

<b>Parameter</b>	<b>Specification</b>
Input Voltage:	Powered from MK292 Module
Stroke Length:	Temposonics II: Up to 300 inches (7620 mm) SE-based Temposonics LP: Up to 48 inches (1219 mm) Temposonics L Series: Up to 120 inches (3048 mm)
Non-linearity:	Temposonics II: $< \pm 0.05\%$ of full scale or $\pm 0.002$ inch ( $\pm 0.05$ mm), whichever is greater SE-based Temposonics LP: $\pm 0.1\%$ of full scale or $\pm 0.004$ in. ( $\pm 0.10$ mm), whichever is greater Temposonics L Series: $0.03\%$ of full scale
Repeatability:	$\pm 0.001\%$ of full scale or $\pm 0.0001$ inch ( $\pm 0.002$ mm), whichever is greater
Operating Temperature:	Head Electronics: - 40 to 150°F (- 40 to 66°C) Sensor Rod: - 40 to 185°F (- 40 to 85°C)
Operating Pressure:	Temposonics II Rod-Style Sensors: 3000 psi continuous, 8000 psi static typical Temposonics L Series Rod-Style Sensors (Model LH): 5000 psi continuous, 10,000 psi static
Outputs (absolute):	Start/stop or PWM configured for <b>external</b> interrogation
Mounting Distances:	Sensor with RS422 output to MK292: 500 meters (1640 ft.) Sensor with PWM output to MK292: 152.4 meters (500 ft.) MK292 to PLC: 25 meters (82 ft.)

*Specifications are subject to change without notice. Consult MTS for verification of specifications critical to your application.*

### 3. System Components

#### 3.1 MK292-Compatible Temposonics Position Sensors

To interface with the MK292, a start/stop or pulse-width modulated output (see figure 3.1) is required from the Temposonics position sensor. The MK292 will convert these signals into a parallel BCD, Gray Code, or binary output.

#### COMPATIBLE SENSORS

##### 3.1.1. Temposonics Position Sensor with Start/Stop Output

Temposonics L Series and LP position sensors provide a direct RS422 compatible start/stop output. Temposonics II position sensors require an RS422 Personality Module (RPM), installed in the sensor head, to produce a start/stop output.

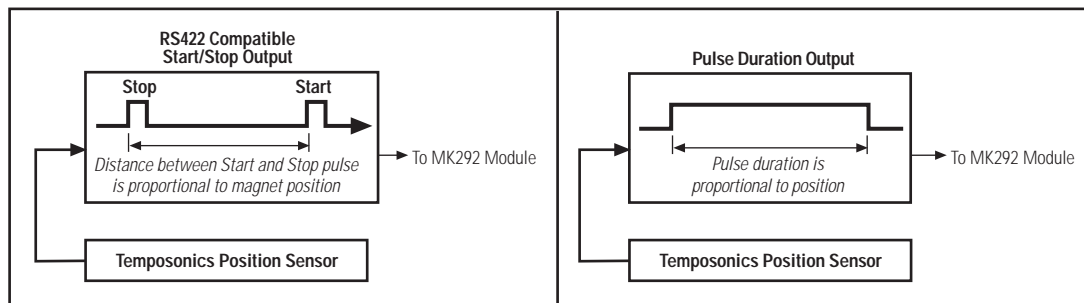
##### 3.1.2. Temposonics Position Sensor with Pulse-Width Modulated (PWM) Output

Temposonics L Series position sensors provide a direct pulse-width modulated output. Temposonics II position sensors require a Digital Personality Module (DPM) to generate a pulse-width modulated output. The DPM is installed in the head of the sensor's electronics enclosure.

When using a Temposonics sensor with a PWM output, "*external interrogation*" is required to interface with the MK292. External interrogation is an option selected at the time of order and is pre-set at the factory.

##### 3.1.3. Temposonics Position Sensor with Synchronous Operation (External Interrogating)

In synchronous operation, an interrogation pulse is supplied to the position sensor from the MK292 module. After supplying the interrogation pulse, the MK292 waits for the sensor's return pulse, then ends the cycle. The time between the launching of the interrogation pulse and the receipt of the return pulse is proportional to the distance between the null or zero position and the movable magnet.



**Figure 3-1**  
**Start/stop and PWM Outputs**

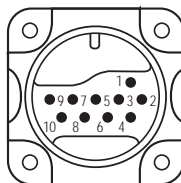
## 4. Connections

### 4.1.1 Temposonics II Position Sensors with DPM or RPM

Table 4-A Connections - Temposonics II Position Sensor

<i>MK292</i> Connections	<i>Pin No.</i>	<i>Wire Color</i> <i>(Striped Leads)</i>	<i>Wire Color</i> <i>(Solid Leads)</i>	<i>Function</i> <i>w/PWM Output</i>	<i>Function</i> <i>w/Start/Stop Output</i>
C32	1	White/Blue Stripe	White	DC Ground	DC Ground
C32	2	Blue/White Stripe	Brown	Frame	Frame
C28	3	White/Orange Stripe	Gray	(-) Gate Out	(-) Start/Stop Pulse
C27	4	Orange/White Stripe	Pink	(+) Gate Out	(+) Start/Stop Pulse
C30	5	White/Green Stripe	Red	+ 15 Vdc	+ 15 Vdc
C31	6	Green/White Stripe	Blue	- 15 Vdc	- 15 Vdc
No Connection	7	White/Brown Stripe	Black	Not Used	Not Used
No Connection	8	Brown/White Stripe	Violet	Not Used	Not Used
C24	9	White/Gray Stripe	Yellow	(+) Interrogation	(+) Interrogation
C25	10	Gray/White Stripe	Green	(-) Interrogation	(-) Interrogation

**NOTE:** Verify if the cable has striped or solid color leads and make connections accordingly.

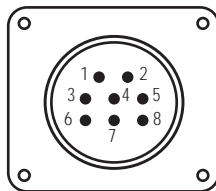


**Figure 4-1**  
**10 Pin 'RB' Style Connector**  
**(Mating Connector: P/N 400755-3)**

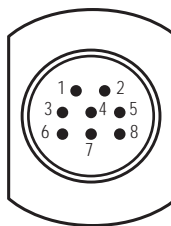
### 4.1.2 SE-based Temposonics LP Position Sensors with Start/Stop Output

Table 4-B Connections - SE-based Temposonics LP Position Sensor

<i>MK292</i> Connections	<i>Sensor</i> <i>Pin No.</i>	<i>Wire Color</i>	<i>Function</i>
C28	1	Blue	Gate (-)
C27	2	Green	Gate (+)
C25	3	Yellow	Interrogation (-)
C24	4	Orange	Interrogation (+)
C30	5	Red	Power, provided by MK292 (+15, ± 10%)
C32	6	Black	Ground
No Connection	7	Drain	Shield Drain Wire
No Connection	8	N/A	N/A



**Figure 4-2a**  
**Integral Connector**  
**Connection Type C,**  
**External View**



**Figure 4-2b**  
**Hanging Connector**  
**Connection Type H or J,**  
**External View**

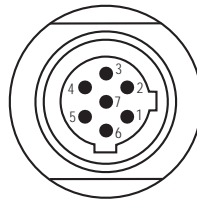
### 4.1.3 Temposonics L Series Position Sensors with Start/Stop Output

**CAUTION!**

When wiring Temposonics L Series sensors, DO NOT connect DC ground to the cable shield or drain wire.

Table 4-C.1 Connections - Temposonics L Series Position Sensor with RG Connector

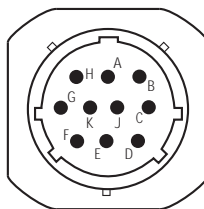
<i>MK292</i>			
<i>Connection</i>	<i>Pin No.</i>	<i>Wire Color</i>	<i>Function</i>
C28	1	Gray	(-) Gate
C27	2	Pink	(+) Gate
C24	3	Yellow	(+) Interrogation
C25	4	Green	(-) Interrogation
C2	5	Red or Brown	Power supplied by MK292 (+ 24 Vdc)
C32	6	White	DC Ground
	7	-	No Connection



**Figure 4-3**  
**RG Connector**

Table 4-C.2 Connections - Temposonics L Series Position Sensor with MS Connector

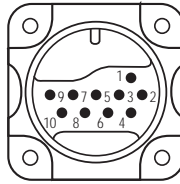
<i>MK292</i>			
<i>Connection</i>	<i>Pin No.</i>	<i>Wire Color</i>	<i>Function</i>
C32	A	White	DC Ground
	B	-	No Connection
C28	C	Gray	(-) Gate
C27	D	Pink	(+) Gate
C2	E	Red	Power supplied by MK292 (+ 24 Vdc)
	F	-	No Connection
	G	-	No Connection
	H	-	No Connection
C24	J	Yellow	(+) Interrogation
C25	K	Green	(-) Interrogation



**Figure 4-4**  
**MS Connector**  
**(Mating Connector: P/N 370013)**

**Table 4-C.3 Connections - Temposonics L Series Position Sensor with RB Connector**

<i>MK292</i>			
<i>Connection</i>	<i>Pin No.</i>	<i>Wire Color</i>	<i>Function</i>
C32	1	White	DC Ground
	2	-	No Connection
C28	3	Gray	(-) Gate
C27	4	Pink	(+) Gate
C2	5	Red	Power supplied by MK292 (+ 24 Vdc)
	6	-	No Connection
	7	-	No Connection
	8	-	No Connection
C24	9	Yellow	(+) Interrogation
C25	10	Green	(-) Interrogation



**Figure 4-5**  
**RB Connector**  
**(Mating Connector: P/N 400755-3)**

**Table 4-C.4 Connections - Temposonics L Series Position Sensor with RO Integral Cable**

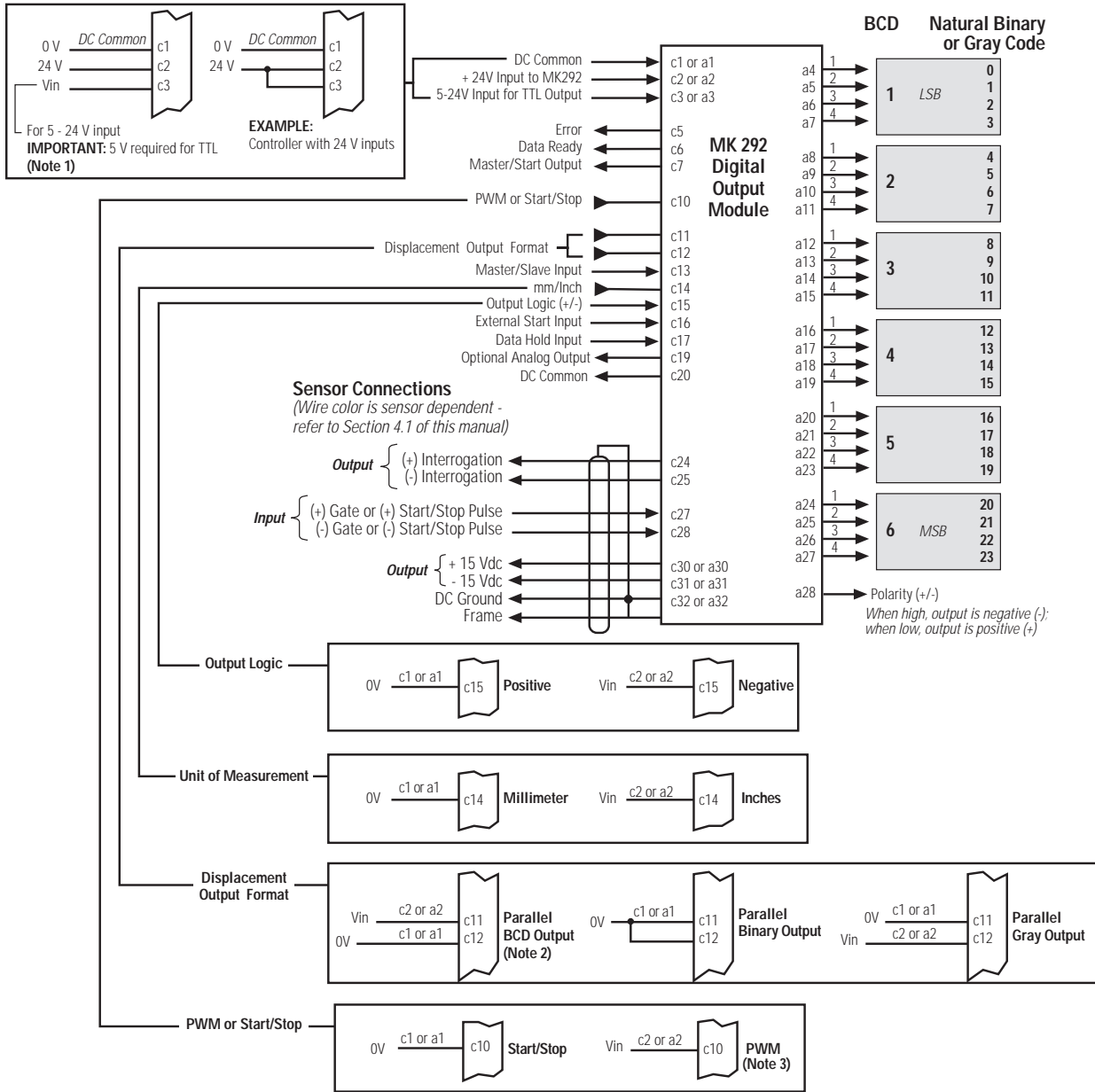
<i>MK292</i>		
<i>Connection</i>	<i>Wire Color</i>	<i>Function</i>
C28	Gray	(-) Gate
C27	Pink	(+) Gate
C24	Yellow	(+) Interrogation
C25	Green	(-) Interrogation
C2	Red or Brown	Power supplied by MK292 (+ 24 Vdc)
C32	White	DC Ground

**Table 4-C.5 Connections - Temposonics L Series Position Sensor with HO Integral Cable\***

<i>MK292</i>		
<i>Connection</i>	<i>Wire Color</i>	<i>Function</i>
C28	White	(-) Gate
C27	Black twisted w/white	(+) Gate
C24	Blue	(+) Interrogation
C25	Black twisted w/blue	(-) Interrogation
C2	Red	Power supplied by MK292 (+ 24 Vdc)
C32	Black twisted w/red	DC Ground

*\*The HO Integral Cable [maximum length 30 feet (9.14 m)] was not available at the time this manual was printed. Please contact the factory for status.*

## 4.2 System Connections



### NOTES:

1. Logic inputs and outputs are relative to voltage level connected to Vin (Pin c3). For example, set Vin to 5 Vdc for TTL, or 24 Vdc for controller with 24 Vdc inputs/outputs.
2. The five digit BCD outputs are limited to stroke lengths  $\leq 7500$  mm when measuring in millimeters. When measuring in inches, BCD output is available for stroke lengths up to 300 inches.
3. When using a PWM output, the sensors must be configured for **external interrogation**.

**Figure 4-6**  
**System Connections**

### 4.3 Functional Inputs/Outputs

---

#### OUTPUTS:

Voltage Level: TTL level to 24 Vdc  
Maximum Current Load: 20 mA (high level)

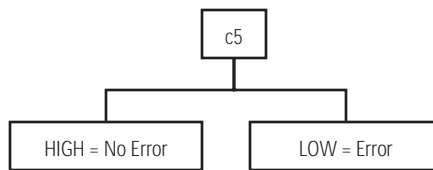
#### INPUTS:

Control Signal Level:  $\geq$  applied  $V_{in}$  level  
Current Load per Input:  $< 1$  mA

#### 4.3.1 Error Output (Loss of Feedback)

Pin: c5

Logic: HIGH: No Error; LOW: Error



**Figure 4-7 Error Outputs**

Errors:

- No sensor magnet
- Sensor magnet not positioned within the active range of sensor
- Malfunction or failure of sensor or module
- Electronic interference

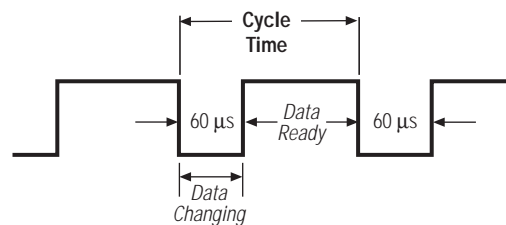
#### 4.3.2 Data-Ready Output (Latch Pulse)

Pin: c6

Logic: HIGH

Ensures that parallel data transfer does not occur during data update (i.e., during change in magnet position). In addition, the data ready output confirms that the data is up-to-date.

The timing of data transfer is illustrated below.



**Figure 4-8 Data Ready**

### 4.3.3 Data-Hold Input (Latch Inhibit)

Pin: c17  
Logic: HIGH

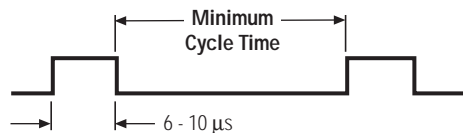
Data Hold is another means, besides Data Ready, to ensure that parallel data transfer does not occur during data update. When Data Hold (C17) is high, data does not update.

### 4.3.4 External Start Input (Features)

Pin: c16  
Logic: HIGH

The External Start Input permits the timing of the measuring cycle (i.e., the interrogation pulses) to originate from an outside source. The Master/Slave Input (see below) logic must be HIGH before the sensor can be interrogated, normally it is set LOW.

Start signals must be between 6 to 10 microseconds in duration and repetition period must exceed the minimum cycle time -- refer to programming section of the manual: (MR) Measuring Range.

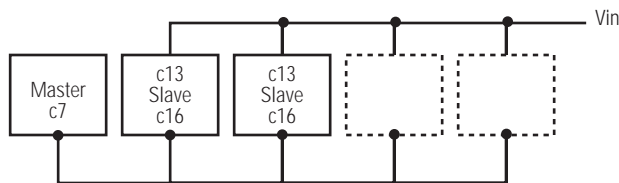


**Figure 4-9 External Start**

### 4.3.5 Master/Slave Input (Features)

Pin: c13  
Logic: HIGH

If an application requires that more than one Temposonics position sensor provide position data simultaneously, the Master/Slave Input may be used. It is essential to identify the longest position sensor as the master device since it possesses the longest cycle time. The master "start" command is switched to output 'c7' and linked to slave output 'c16' (External Start Input).



**Figure 4-10 Master/Slave**

## 5. System Parameters

After the MK292 Digital Output Module is installed and connected to the Temposonics position sensor, system parameters must be set before start-up. When setting the system parameters, you must be aware which electronics module is installed in the Temposonics position sensor. Verify that the sensor has either a **start/stop or PWM output**. If the sensor has a PWM output, also verify that it is configured for **external interrogation**. Contact an MTS Applications Engineer if you have any questions regarding the configuration of your sensor or how to interface to the MK292 unit.

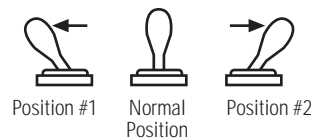
The system parameters for each configuration are indicated below:

<b>SYSTEM PARAMETERS</b> (Sensor with PWM Outputs)			<b>SYSTEM PARAMETERS</b> (Sensor with Start/Stop Outputs)		
<b>RUN</b>	<	Programming Mode	<	<b>RUN</b>	
<b>REC</b>	<	Pulse Duration	<	<b>N/A</b>	
<b>NOTE:</b> Pulse Duration (REC) only applies to systems that are using sensors with a PWM output.					
<b>SC</b>	<	Scaling Factor	<	<b>SC</b>	
<b>RE</b>	<	Resolution	<	<b>RE</b>	
<b>MR</b>	<	Measuring Range	<	<b>MR</b>	
<b>ZERO</b>	<	Null Adjustment	<	<b>ZERO</b>	

System parameters are set via the front panel of the MK292 using the programming and BCD switches.

### • Programming Switch

This momentary toggle switch is located at the bottom of the front panel. It has two activation positions: #1 and #2. Programming Modes are accessed by manipulation of this switch as defined in the Programming section of this manual.



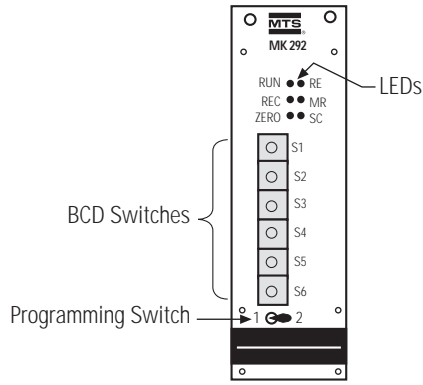
**Figure 5-1**  
**Programming Switch Positions**

When the Programming Switch is pushed into either Position #1 or Position #2 it will automatically return to the center (normal) position when released.

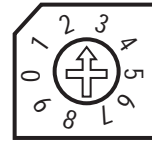
- **BCD Switches (S1-S6)**

The six rotary switches, S1 (least significant digit) to S6 (most significant digit), are used to set parameter values. A screw driver or adjusting tool is used to set the switches.

The input values are checked against the actual values as indicated by the customer provided controller display.



**Figure 5-2**  
**Front Panel of MK292 Module**



**Figure 5-3**  
**BCD Switch**

- **LEDs**

There are six LEDs, one red and five green, which give visual indication of the operating condition and programming mode of the MK292.

1. RED (continuous light) = System in operation mode
2. RED (flashing light) = Transition to programming mode
3. GREEN (continuous light) = Indication of selected parameter
4. GREEN (flashing light) = Programming mode is activated – parameter settings can be changed via BCD switches S1-S6.
5. GREEN (fast flashing light) = Input error

## 6. Short Form Programming Procedure

---

- **Programming Mode**

Hold the programming switch in **Position #1** (see Fig. 6.1) until the **'RUN'** LED begins to flash ( $\approx 3$  sec.) Programming Mode is set up.

- **Selection of System Parameters**

To select desired parameter, momentarily toggle the programming switch to **Position #1** and release; an LED will light. Repeat until the LED is lit next to desired parameter.

**NOTE:**

*You may cycle through and check the parameters by observing the controller display as you repeatedly put the programming switch in Position #1.*

*To change a parameter: Select desired parameter, then simply hold the programming switch in Position #2 until the LED flashes ( $\approx 3$  sec.). Change parameter using the BCD switches.*

- **Parameter Adjustment**

Enter desired values using BCD switches S1-S6 (S1 represents the least significant digit). Rapid flashing of the green LED indicates input error.

- **Parameter Setup**

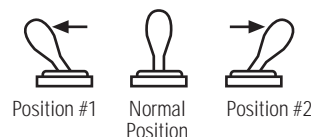
To store a newly set parameter, hold the programming switch in **Position #2** (see Fig. 6.1) until the LED of the next parameter is activated ( $\approx 3$  sec.)

**NOTE:**

*If the value cannot be stored, momentarily hold the programming switch in Position #1, and repeat, until you cycle through to the desired parameter.*

- **Operation Mode**

Hold the programming switch in **Position #1** until the red **"RUN"** LED is activated. This indicates that the Programming Mode has been exited and the Operation Mode is ready.



**Figure 6-1**  
**Programming Switch Positions**

For detailed instructions on programming the MK292 Digital Output Module, refer to Section 7 of this manual.

## 7. Detailed Programming Procedure

---

### 7.1 (RUN) Programming Mode / Red LED

---

During initial start-up, the red 'RUN' LED will flash. This indicates that the MK292 is in the programming mode and input parameters are required for operation.

If the 'RUN' LED is on, but not flashing, this means that parameters have already been set. If parameters must be changed, the programming mode must be accessed, as follows:

<b>RUN</b>	Hold programming switch in Position #1 until 'RUN' LED flashes ( $\approx$ 3 sec.)
------------	--

ADJUST

### 7.2 (REC) Pulse Duration / Green LED

---

**NOTE:**

*This parameter only applies to systems that have a Temposonics position sensor with a PWM output. In the procedure, this step will not occur if the MK292 is configured for a start/stop output.*

Temposonics sensors with a PWM output are capable of “circulations”, meaning that the interrogation and return signals can be recirculated a specific number of times. This lengthens the duration of the PWM output from the sensor and the counting time of the MK292; the result is increased resolution.

The number of circulations is determined at the time of order and is reflected in the sensor's model number. Refer to the appropriate ordering guide for the sensor that you are using to determine the circulation count. If you have any questions regarding this, contact an MTS Applications Engineer.

- |            |
|------------|
| <b>REC</b> |
|------------|
- 1) Hold the programming switch in Position #2 until the 'REC' LED is flashing ( $\approx$  3 sec.)
- ADJUST 2) Enter the Pulse Duration (recirculation value) using BCD switches S1-S6.

**Example:**

**NOTE:**  
*The chart below defines the MK292-programmable resolutions. It is important to note that with resolution finer than 0.0002 in., instabilities will be detected on the Least Significant Bits.*

**Resolution vs. Circulations**

<i>Maximum</i>	<i>Minimum</i>	<i>Circulation Count</i>
See note above	0.00025	16
0.00025	0.0005	8
0.0005	0.001	4
0.001	0.002	2
0.002	0.004	1

**Maximum Resolution Formulas:**

- Resolution in millimeters =  $(0.0508 \div \text{Circulation Count})$
- Resolution in inches =  $(0.002 \div \text{Circulation Count})$

**Switch Setting: PWM Output (circulations)**

<i>BCD Switch</i>	<i>Circulations: 4</i>	<i>Circulations: 16</i>
S1	4	6
S2	0	1
S3	0	0
S4	0	0
S5	0	0
S6	0	0

- |            |
|------------|
| <b>REC</b> |
|------------|
- 1) Hold the programming switch in Position #2 until the 'SC' LED is flashing ( $\approx$  3 sec.)
- ADJUST

The MK292 is now ready to accept the next parameter – Scale Factor (SC).

### 7.3 (SC) Scaling Factor / Green LED

Each Temposonics position sensor has its own specific scale factor (gradient) which describes the velocity of the torsional strain pulse through the waveguide medium (refer to 'Principle of Operation'). The gradient is indicated on the sensor's label. Upon initial start-up or when replacing sensors, this value must be set to recalibrate system.

#### IMPORTANT

##### **Scale Factor or Gradient**

For stroke lengths defined in inches (Pin c14 set for inches), the scale factor or gradient is described in microseconds per inch. This value is indicated on the sensor's label (see Fig. 7.3).

For stroke lengths defined in millimeters (Pin c14 set for millimeters), the scale factor or gradient is described in meters per second.

The formula to convert  $\mu\text{s}/\text{in}$ , to  $\text{m}/\text{s}$  is as follows:

$$(\text{Scale in m/s}) = 25,400 \div (\text{Scale in } \mu\text{s.in.})$$

##### **Example:**

Scale (Gradient) = 8.94371  $\mu\text{s}/\text{in}$ .

$$25,400 \div 8.94371 \mu\text{s}/\text{in} = 2839.98 \text{ meters/second}$$

SC

- ADJUST
- 1) Momentarily tap the programming switch to Position #1, the 'SC' LED will light.
  - 2) Hold the programming switch in Position #2 until the 'SC' LED begins to flash ( $\approx 3$  sec.)
  - 3) Enter the scale factor indicated on the sensor label using the BCD switches (S1 - S6).

**Example: Gradient = 8.94371**

<b>BCD Switch #</b>	<b>Settings</b>
S1	1
S2	7
S3	3
S4	4
S5	9
S6	8

**SC** Hold the programming switch in Position #2 until the 'RE' LED is lighted ( $\approx$  3 sec.)  
 SETUP

The MK292 is now ready to accept the next parameter – Resolution (RE).

#### 7.4 (RE) Resolution / Green LED

The resolution that can be achieved by the MK292 is dependent on the input from the Temposonics position sensor. The chart below indicates the range of resolutions depending on sensor type. Note that sensors with PWM output must be set for the appropriate number of circulations to achieve desired output resolution.

##### RESOLUTION

##### *Start/Stop Output*

Range: 0.1 in. to 0.002 in. or 2.54 mm to 0.05 mm

##### *PWM Output*

Range: 0.1 in. to 0.0002 in. or 2.54 mm to 0.005 mm

(Note: Refer to Resolution vs. Circulation Chart, page 16)

**RE** 1) Hold the programming switch in Position #2 until the 'RE' LED begins to flash ( $\approx$  3 sec.)  
 ADJUST 2) Enter the desired resolution using BCD switches S1 - S6.

**Table 7A**

SWITCH SETTINGS / RESOLUTION IN INCHES						
Switches	0.0002 in.	0.0004 in.	0.002 in.	0.004 in.	0.02 in.	0.039 in.
S1 (0.00X)	2	4	0	0	0	0
S2 (0.00X)	0	0	2	4	0	9
S3 (0.0X)	0	0	0	0	2	3
S4 (0.X)	0	0	0	0	0	0
S5	0	0	0	0	0	0
S6	0	0	0	0	0	0

**Table 7B**

SWITCH SETTINGS / RESOLUTION IN MILLIMETERS						
Switches	0.005 mm	0.01 mm	0.05 mm	0.1 mm	0.5 mm	1.0 mm
S1 (0.00X)	5	0	0	0	0	0
S2 (0.0X)	0	1	5	0	0	0
S3 (0.X)	0	0	0	1	5	0
S4 (X.0)	0	0	0	0	0	1
S5	0	0	0	0	0	0
S6	0	0	0	0	0	0

**RE** Hold the programming switch in Position #2 until the 'MR' LED begins to flash ( $\approx$  3 sec.)  
 SETUP

The MK292 is now ready to accept the next parameter – Measuring Range (MR)

## 7.5 (MR) Measuring Range / Green LED

The measuring range or "stroke length" of the sensor must be set accurately to optimize the interdependence of the other parameters. This value is indicated on the sensor label as "stroke" and will be in either inches or millimeters.

**NOTE:**

*Pin c14 of the MK292 permits you to select the unit of measurement (i.e., inches or millimeters) and must be wired accordingly (refer to section 4.2).*

**MR**

- 1) Hold the programming switch in Position #2 until the 'MR' LED begins to flash (≈ 3 sec.)  
 ADJUST 2) Enter the measuring range using BCD switches S1 - S6.

**Example:**

<b>INCHES</b>	
Measuring Range: 120.5 inches	
<i>Switch (in.)</i>	<i>Setting</i>
S1 (0.1)	5
S2 (1.0)	0
S3 (10)	2
S4 (100)	1
S5 (n/a)	0
S6 (n/a)	0

<b>MILLIMETERS</b>	
Measuring Range: 1525 millimeters	
<i>Switch (mm)</i>	<i>Setting</i>
S1 (1.0)	5
S2 (10)	2
S3 (100)	5
S4 (1000)	1
S5 (n/a)	0
S6 (n/a)	0

**NOTE:**

*When the measuring range is set, the measuring frequency and system update time is also set. Refer to the tables below to see the relationship of measuring range, frequency, and update time.*

**Update Time Formula:**

$$Tud = [(Lm + 120 \text{ mm}) (13) (N)] \div 36$$

Where:

Update Time (in milliseconds) = Tud

Length in mm = Lm

Circulation Count = N

**NOTE:**

*When using inches, use the following formula to convert inches to millimeters:  
 Inches x 25.4*

**MR**

- 1) Hold the programming switch in Position #2 until the 'ZERO' LED begins to flash (≈ 3 sec.)  
 SETUP

The MK292 is now ready to accept the next parameter -- Null Adjust (ZERO).

## 7.6 (ZERO) Null Adjust / Green LED

---

Null adjust allows you to set the mechanical ZERO position anywhere within the active measuring range of the position sensor. Move the sensor magnet to the desired ZERO position and proceed as follows:

**ZERO** 1) Hold the programming switch in Position #2 until the 'ZERO' LED begins to flash ( $\approx$  3 sec.)  
ADJUST

*The displacement output indicates position without the offset calculation*

2) Set switches S1-S6 to ZERO position.

**ZERO** 1) Hold the programming switch in Position #2 to restart programming sequence. ( $\approx$  3 sec.)  
SET UP

**NOTE:**

*If a set value is overwritten, the programming mode has to be set again by repeatedly tapping the dip switch to position #1.*

## 7.7 (ZERO) Offset

---

As an alternative to the ZERO/NULL adjust, a ZERO/NULL offset can be programmed within a range of -49.9999 to +49.9999 inches. The value depends on the pre-set resolution of the position sensor. The offset is set by using S6 only.

<i>Positive Offset</i>	<i>Negative Offset</i>
0 = +0	5 = -0
1 = +1	6 = -1
2 = +2	7 = -2
3 = +3	8 = -3
4 = +4	9 = -4

Forward Acting - Positive offset counts down when magnet is moved to the head and counts up when moved to the tip.

Reverse Acting - Negative offset counts up when magnet is moved to the head and counts down when moved to the tip.

Move the magnet to the desired mechanical start position and calibrate the offset as follows:

- OFFSET** 1) Hold the programming switch in Position #2 until the 'ZERO' LED begins to flash ( $\approx$  3 sec.)  
ADJUST

*The displacement output indicated position without the offset calculation*

- 2) Enter the desired offset value using BCD switches S1-S6.

**EXAMPLE: Switch Settings S1-S6 for Offset Value**

POSITIVE OFFSET (in inches)				
BCD Switch	+00.3571	+04.5841	+03.5705	+45.8405
S1	1	1	5	5
S2	7	4	0	0
S3	5	8	7	4
S4	3	5	5	8
S5	0	4	3	5
S6	0	0	0	4

NEGATIVE OFFSET (in inches)				
BCD Switch	-00.3571	-04.5841	-03.5705	-45.8405
S1	1	1	5	5
S2	7	4	0	0
S3	5	8	7	4
S4	3	5	5	8
S5	0	4	3	5
S6	5	5	5	9

- OFFSET** 1) Hold the programming switch in Position #2 to restart programming sequence. ( $\approx$  3 sec.)  
SET UP

**NOTE:**  
*If a set value is overwritten, the programming mode has to be set again by repeatedly tapping the dip switch to Position #1.*

## 7.8 (RUN) Operation Mode / Red LED

---

**RUN**  
SETUP

1) Hold the programming switch in Position #1 until the 'RUN' LED begins to flash ( $\approx 3$  sec.)

The Programming Mode is exited and all parameter settings are stored in an EEPROM within the MK292 module. You are now in Operation Mode.

## 8. Optional Analog Output for the MK292 (for Recording Purposes Only)

**NOTE:**  
The analog output is available as an option and must be specified at the time of order. An additional analog sub-print is required.

The analog output option functions in two operational modes:  
1. Normal (NORM)  
2. Programmable Adjustment (PROG)

**WARNING!**  
When powering down during analog operation, switch must remain in programming mode or all parameters will be lost.

Operation mode is selected with the switch on the analog sub-print board (see Fig. 8.1).

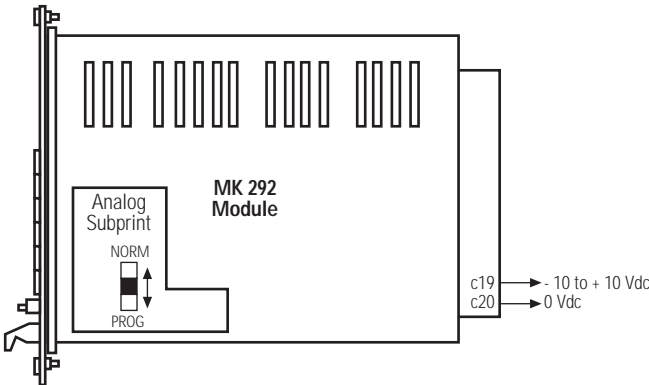


Figure 8-1

### 8.1 Operation Mode 1 (Normal)

Analog Sub-print Switch (S1) = NORM

The analog output configuration is defined by the zero position and measuring range of the sensor. The three possible configurations are illustrated in Fig. 8.2.

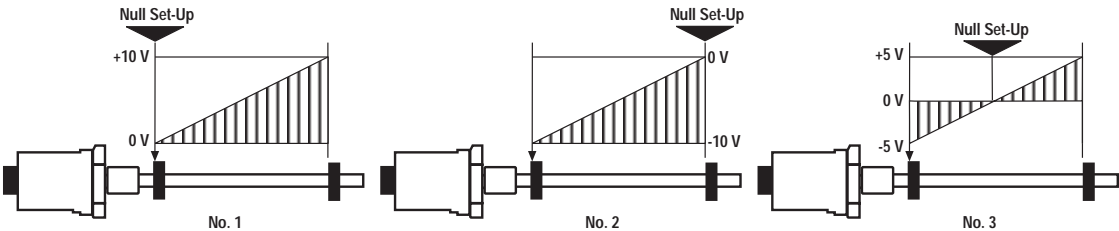


Figure 8-2

If the magnet leaves the defined measuring range of the sensor, the system will indicate the following outputs:

1. If the magnet leaves the measuring range moving towards the end of the sensor rod, the output voltage will be **NEGATIVE**.
2. If the magnet leaves the measuring range moving toward the electronics head of the sensor, the output will be a constant **+10V**.

## 8.2 Operation Mode 2 (Programmable Adjustment)

---

The analog output configuration can be set-up by defining the desired output range of the sensor with two set-points (SP1 and SP2).

### IMPORTANT NOTES:

- *SP1 and SP2 must be within the valid measuring range*
- *SP1 must be located nearer the sensor head than SP2*
- *SP1 and SP2 can have output values between -10 V and +10 V*

### Switch S1 = ON (PROG)

#### SP1 Programming:

---

- 1.) Move the magnet to the desired SP1 position.
  - 2.) Hold the programming switch in Position #1 until the **RUN** LED begins to flash ( $\approx$  3 seconds)  
Programming Mode is set up.
  - 3.) Momentarily toggle the programming switch to Position #1 and release and repeat until **ZERO + SC** become lit.
  - 4.) Hold the programming switch in Position #2 until **SC** begins to flash ( $\approx$  3 seconds). **ZERO** is also lit.
  - 5.) Enter the desired analog out at SP1 using the BCD switches (S1 = least significant bit, S5 = most significant bit).
  - 6.) Hold the programming switch in Position #2 until **SC** is lit ( $\approx$  3 seconds). **ZERO** is also lit.
  - 7.) The output value at SP1 is now stored.
- 

### NOTE:

*Setting up a value outside the valid voltage range will be detected and SC will flash rapidly to indicate an error.*

#### SP2 Programming:

---

- 1.) Move the magnet to the desired SP2 position
  - 2.) Hold the programming switch in Position #1 until the **RE** LED begins to flash ( $\approx$  3 seconds). **ZERO** is also lit.
  - 3.) Enter the desired analog out at SP2 using the BCD switches (S1 = least significant bit, S5 = most significant bit).
  - 4.) Hold the programming switch in Position #2 until **SC** is lit ( $\approx$  3 seconds). **ZERO will no longer be lit.**
  - 5.) Hold the programming switch in Position #1 until the **RUN** LED is lit ( $\approx$  3 seconds).  
The output value at SP2 is now stored and the system has entered the Operations Mode.
- 

### NOTE:

*Setting up a value outside the valid voltage range will be detected and RE will flash rapidly to indicate an error.*

### EXAMPLE, BCD Switch Settings

<i>SP1 = + 7.565 V</i>	<i>SP2 = - 9.480 V</i>
S1 = 5	S1 = 0
S2 = 6	S2 = 8
S3 = 5	S3 = 4
S4 = 7	S4 = 9
S5 = 0	S5 = 0
S6 = 0	S6 = 9

**NOTE:**

*To configure a negative setpoint value:  $S6 \geq 5$ .*



**MTS Systems Corporation**

Sensors Division  
3001 Sheldon Drive  
Cary, NC 27513 USA  
Phone: 800-633-7609  
Fax: 919-677-0200

**MTS Sensor Technologie  
Gmb and Co. KG**

Auf dem Schüffel 9  
D-58513 Ludensheid  
Federal Republic of Germany  
Phone: +49-23-5195870  
Fax: +49-23-5156491

**MTS Sensors Technology Corp.**

Izumikan Gobancho  
12-11 Gobancho  
Chiyoda-ku, Tokyo 102  
Japan  
Phone: +3-3239-3003  
Fax: +3-3262-7780

Temposonics is a registered trademark of MTS Systems Corporation.  
All Temposonics products are covered by US patent number 5,545,984.  
Other patents pending.



0797 550414 Revision B  
© 1997 MTS Systems Corporation