

Data Sheet

L-Series Analog + Digital

Magnetostrictive Linear Position Sensors

Document Part No.
05012010



A Compact Sensor for Hydro Cylinders

- Absolute Sensor
- Non-contact Measurement
- Modular Construction
- Stable Design
- Highest Durability
- Measuring Range: 50 - 5000 mm
- Linearity: Better 0,02 %
- Repeatability: 0,001 %
- Direct Analog Output (V/mA): 100% field adjustable
- Digital Pulse Output, Start-Stop

Temposonics® LD

Analog + Digital

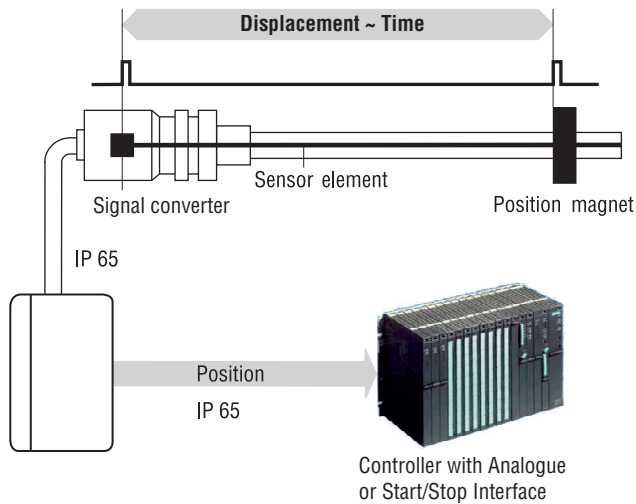

The absolute Temposonics linear position sensors are based on the Temposonics developed magnetostrictive measurement principle. That combines various magneto-mechanical effects and uses the physical high precise speed-measurement of an ultrasonic wave (torsion pulse in its sensor element) for position detecting. The integral signal processing transforms the measurements into analogue or digital standardized outputs.

The *contactless* principle - an external movable magnet marks the position - eliminates the wear, noise and erroneous signal problems and guarantees the best durability without any recalibration.

Measured Variables
Measuring Range
Output

Displacement
50 - 5000 mm
Voltage: 0...10 VDC or 10...0 VDC
(Minimum load: > 5 kOhm)
Current: 4(0)...20 mA or 20...4(0) mA
(Min/Max. 0 / 500 Ohm)

Adjustment of NULL and SPAN
Resolution

Start/Stop pulse: RS422 Differential signal
Analogue: 100% of measuring range (F.S.)
Analogue: Infinite, restricted by output ripple
Digital: 0,1 mm; 0,01 mm (controller depending)

Linearity
Repeatability
Update Frequency
Connection Type
Input Voltage
Current Drain
Ripple
Temperature Coefficient
Electric Strength
Operating Temperature
Dew Point, Humidity
EMV-Test

< ± 0,02 % F.S. (Minimum ± 50 µm)
< ± 0,001 % F.S.
Analogue: 1kHz / Digital: controller dependent
Cable outlet
24 VDC (-15 / +20 %)
100 mA typical
< 1 % peak to peak
< 40 ppm/ °C
500 V (DC ground to machine ground)
-40 °C...+75 °C
90 % rel. humidity, no condensation
Electromagnetic emission EN 50081-2; Electromagnetic immunity EN 50082-2

Shockrating
Vibration Rating
Mounting
Magnet speed
Sensor rod + flange
- Pressure Rating
Sensor Electronic Housing
Sealing
Sensor Installation
Magnet Type

EN 6100-4-2/3/4/6 Level 3/4 Criteria A,
LD-sensor installed in a ground metal housing
100 g, 6 ms / IEC-Standard 68-2-27
10 g, 10 - 2000 Hz / IEC-Standard 68-2-6
Any orientation
Any
Stainless steel 1.4301 / AISI 304
350 bar, 700 bar peak pressure
Aluminium diecasting housing
IP 65
Fitting flange or thread M18 x 1,5
Ring magnet

Temposonics® LD

The compact position sensor system was designed for installation in hydraulic cylinders, specifically for use in standard clevis head cylinders or any space limited cylinder applications.

- The pressure proof stainless steel sensor rod with fitting or threaded flange protects the sensing element in which gives rise to the measurement signal. It fits into the bored piston rod.

- The external standard industrial housing accommodates the modular electronic interface with active signal conditioning. The sensor electronic is connected to the basic sensor via inside terminal screws and to the controller with integrated cable outlet.
- The position magnet, the only moving part is mounted on the piston bottom. The permanent magnet travels wearfree and contactless along the stationary sensor tube. Its magnetic field starts the measurement signal through sensor's rod wall.

LD with fitting flange

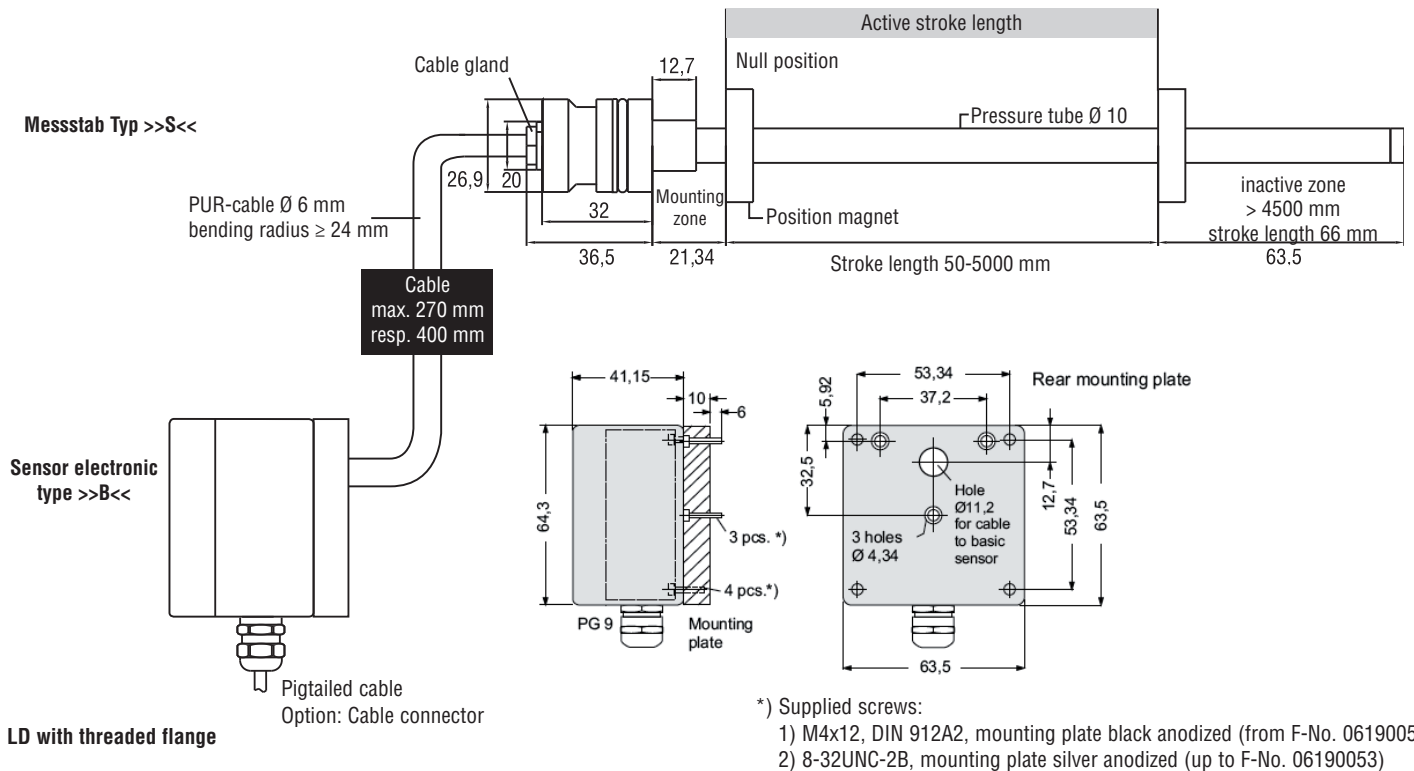

LD with threaded flange

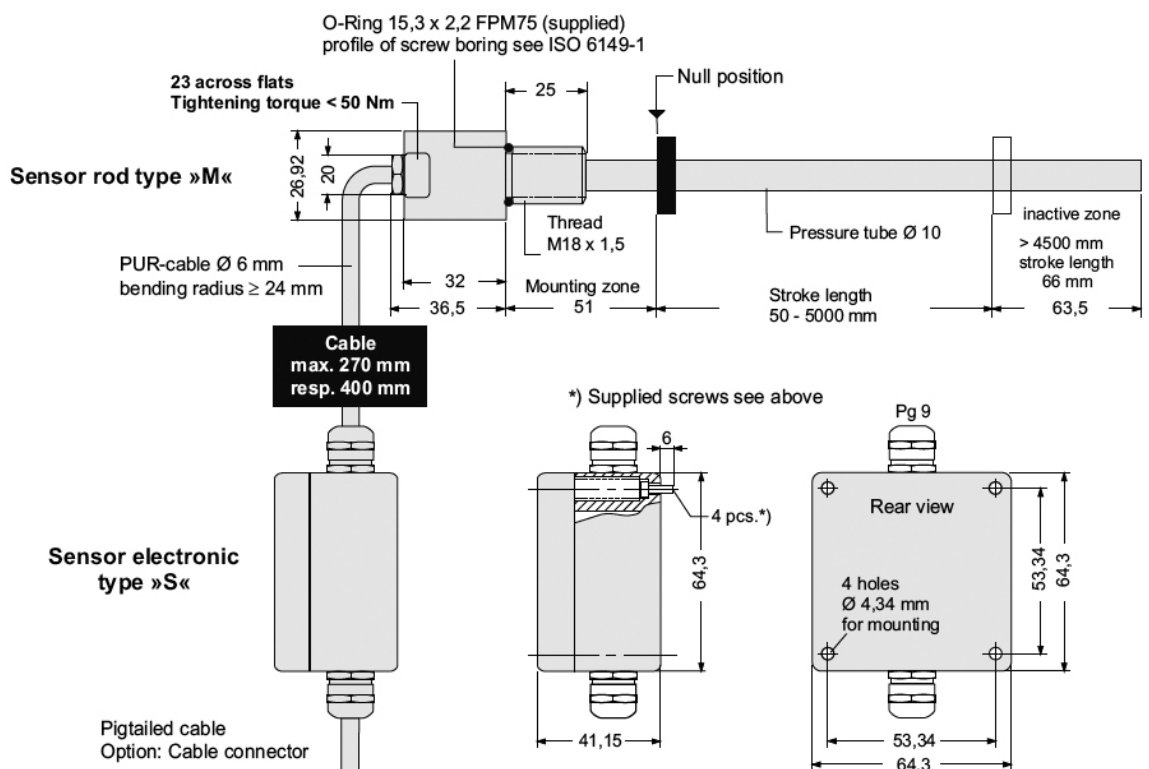

Temposonics® LD

Analog + Digital

Analog Output

Temposonics® LD sensors provide direct analog outputs, including voltage (0-10 V) and current (4-20 or 0-20 mA), forward and reverse acting. Resolution is only limited by the output ripple. Since the outputs are direct, no signalconditioning electronics are needed when interfacing with controllers or meters.

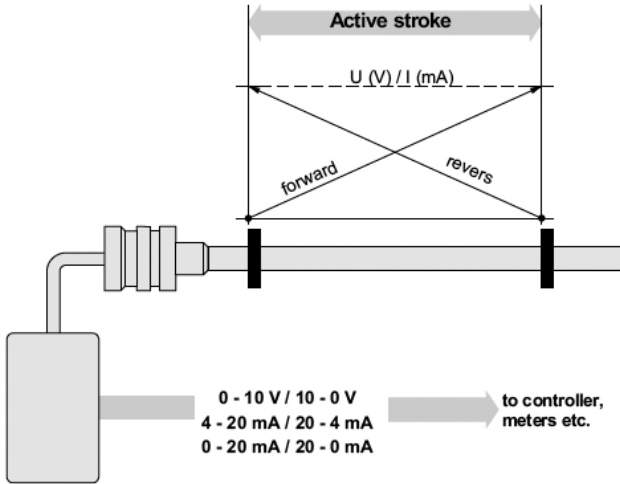

Digital Start/Stop pulse

Digital LD sensor is equipped with a start/stop output. The sensor requires a start signal from an external indicator in onsite control system and returns a signal, corresponding to the magnet position. The time elapsed between the two signals is proportional to the magnet position, i.e. to the displacement. Time measurement is by the indicator and used for calculating the position value. Generation and evaluation of the start/stop pulse is made by a customized Start/Stop interface module of many controller companies.

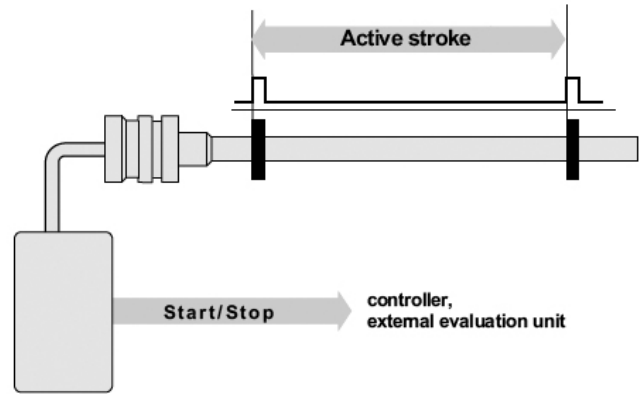

Sensor field programming

LD sensors are preconfigured at the factory by model code designation. If needed, Temposonics offers different external service tools for modifying sensor parameters inside the **active electrical stroke** (50 mm minimum clearance between setpoints) via the standard connection cable. There is no need to open the sensors electronics.

Following tools are available:

1. Handheld-Programmer G-Analog

for setups of measuring length inside the ordered output by pushing up/down-buttons.



Logic diagram Start/Stop

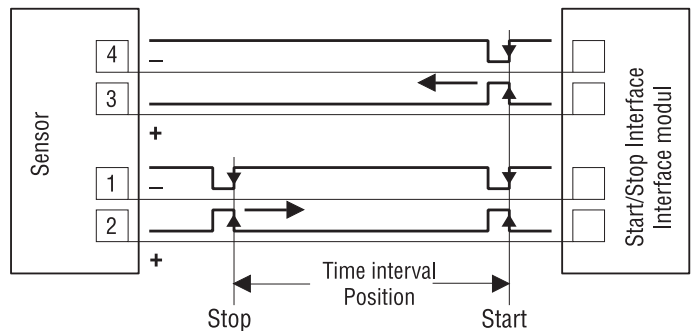

2. PC-Programmer G-Analog

This hardware converter is required to communicate via serial port of Windows PC to the sensor. Customized settings are possible by using a Temposonics programming software (CD-ROM) for:

1. Null and Span
2. Forward and reverse acting
3. Output: Voltage/Current output values encl. range

Cylinder installation

Temposonics® LD is designed for installation into hydraulic cylinders. Mounting of a LD sensor requires the use of a O-ring (black) and a backup-ring (orange). Both are supplied with the sensor. The sensor will be fixed via special screw.

Interconnection cable

When mounted in the manner as shown below, interconnection cable is shielded according to EMC standard at the cylinder end cap. However, when the LD sensor is mounted in an alternative way, proper care must be taken to shield the interconnection cable.

When installing the sensor in the cylinder notice following:

- Magnet must not slide along the sensor tube.
- The bore in the piston rod and type of sealing ate determined by cylinder manufacturers as that depend on hydraulic pressure and piston velocity. We recommend 13 mm bore diameter at minimum. Do not exceed peak pressure.
- Protect sensor rod from wear.

Mounting ring magnet

For accurate position measurements mount the magnet with non-magnetizable material (screws, etc.).

Rod style »S« with Electronics Housing style Typ »B«

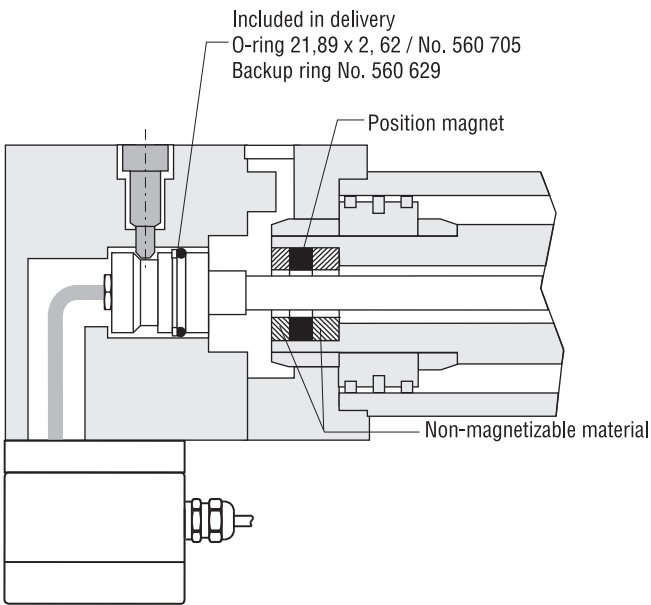

**Example mounting detail:
Setscrew 8 M6 - ISO 7379 with
internal hexagon**

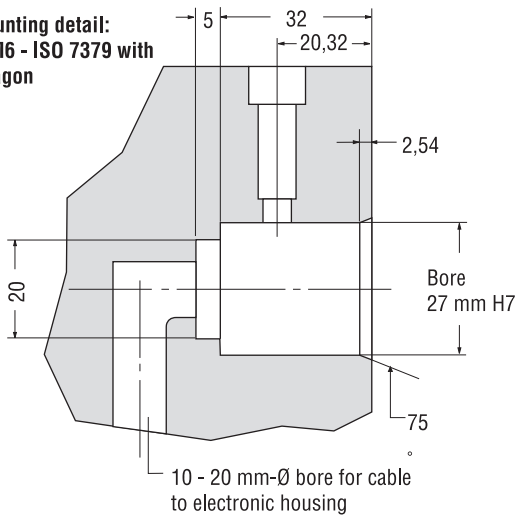

Monting Sensor electronic type »B«

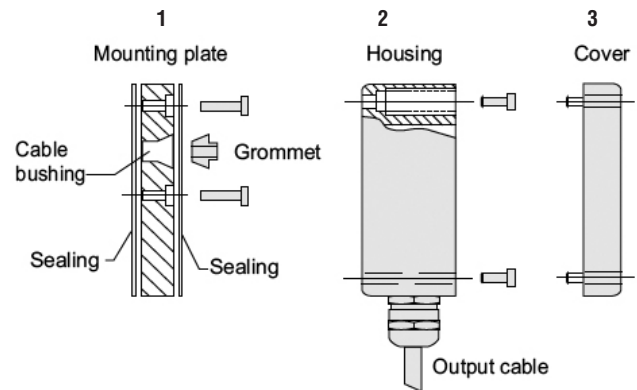

Minimum tolerances for magnetizable material

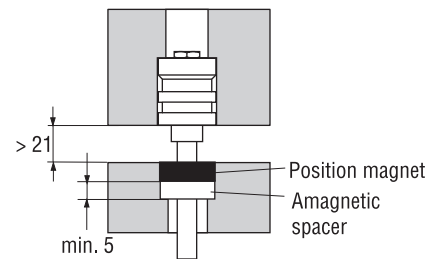

Detail: Flange

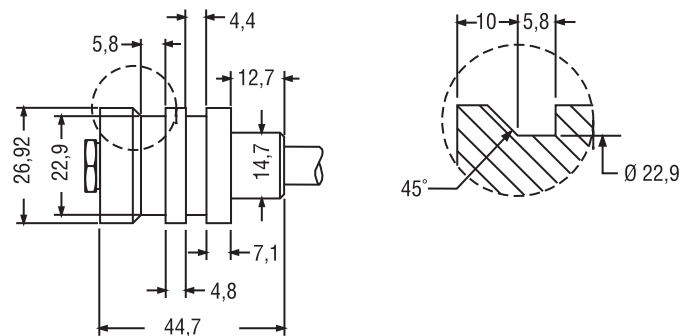

⚠ ATTENTION

Only the mounting of sensorsystem as shown here fulfill the EMC standards of Electromagnetic Emission and Immunity.

Sensor Electronics Housing

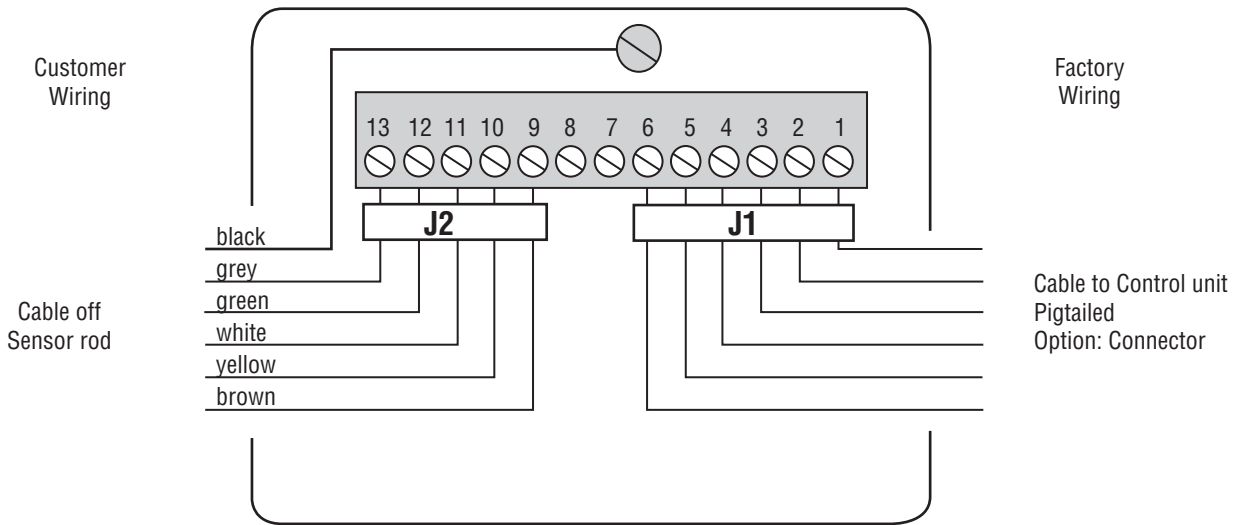

Terminal	Colour	Function
9	brown	V in
10	yellow	SE out
11	white	GND
12	green	WG (-)
13	grey	WG (+)
Screw	black	Frame GND

⚠ For side entry housing connect shield on EMC cable gland

1. Start/Stop Output

Terminal	Colour	Function	Option: Connector
1	white	DC Ground (0 V)	Pin 6
2	pink	Stop (+)	Pin 2
3	yellow	Start (+)	Pin 3
4	grey	Stop (-)	Pin 1
5	green	Start (-)	Pin 4
6	brown	+24 VDC	Pin 5



2. Analog Output

Terminal	Colour	Function	Option: Connector
1	white	DC Ground (0V)	Pin 6
2	pink	DC Ground	Pin 2
3	green	PC Programmer only	Pin 4
4	grey	0-10, 10-0 V, 4(0)-20, 20-(0)4 mA	Pin 1
5	yellow	PC Programmer only	Pin 3
6	brown	+24 VDC	Pin 5

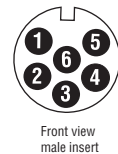

⚠ Wiring of 10-0 V and 20-4(0) mA outputs is valid for LD sensors from fabrication # (F-No.) 0546 xxxx.

Cable gland PG 9-EMC

EMC standard screwed cable gland for shielded cable. Simply to handle, as the cable shield must be removed backup over the plastic insert.

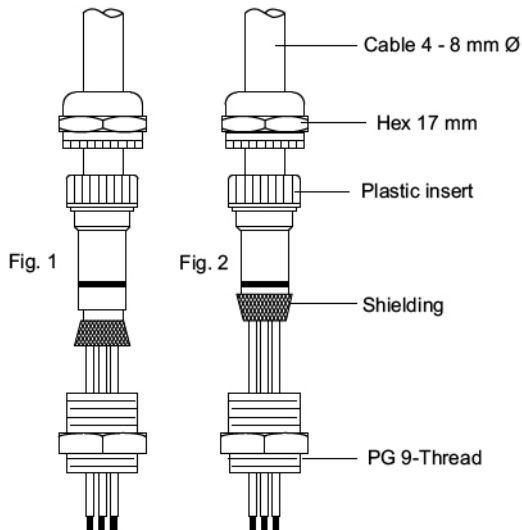

Typical 4 - 20 mA wiring

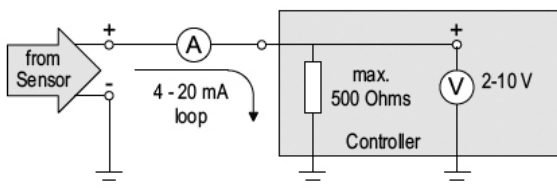

Typical Grounding

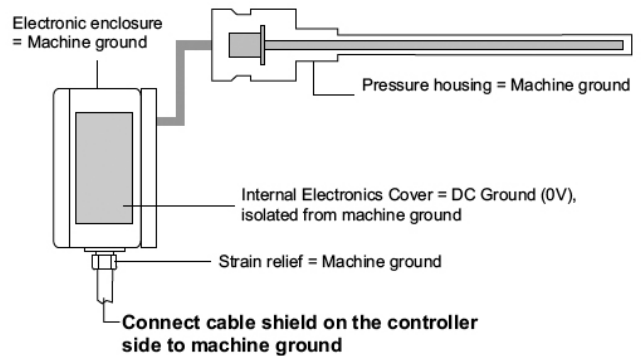

⚠ Cable shield and DC Ground have to be isolated separately!

Temposonics® LD

Sensor rod style

- S - Fiting flange (with housing »B« only)
- M - Threaded flange (with housing »S« only)

Sensor electronic housing style

- B - Bottom cable entry
- S - Side cable entry

Cable type electronic housing

- R - PVC-cable
- H - PUR-cable

Cable outlet

- PT - Pigtailed
- D6 - Cable with 6 pin male connector

Cable length, electronic housing

- 02 - 2 meters, Standard
- 01-10 - 01 up to 10 meters

Measuring length

0050 - 5000 mm
(up to 1000 mm in 50 mm steps; up to 5000 mm in 250 mm steps; **Option:** In 5 mm steps)

Input voltage

2 - +24 VDC

Output signal

- R0 - Start/Stop
- V8 - 0-10 V
- V9 - 10-0 V
- A4 - 4-20 mA
- A5 - 20-4 mA
- A6 - 0-20 mA
- A7 - 20-0 mA

Integral cable length of Sensor rod

- L1 - 270 mm
- L2 - 400 mm

Lieferumfang:

- Messstab
- Sensorelektronik

**Magnete und Zubehör
bitte extra bestellen.**

Position magnets (order seperately)

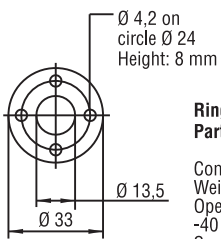

Ring magnet OD33
Part No. 201 542-2

Composite PA-Ferrite-GF20
Weigth ca. 14 g
Operating temperature:
-40 ... +100°C
Surface pressure max. 40 N/mm²
Fastening Torque for M4 screws max. 1 Nm

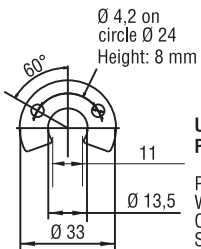

U-Magnet OD33
Part No. 251 416-2

PA-Ferrit-GF20
Weigth ca. 11 g
Operating temperature: -40 ... +100°C
Surface pressure max. 40 N/mm²
Fastening torque for M4 screws max. 1 Nm

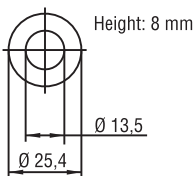

Ring magnet OD25,4
Part No. 400 533

Composite: PA-Ferrite
Weigth ca. 10 g
Operating temperature:
-40 ... +100°C
Surface pressure max. 40 N/mm²

Male connector M16 wired on cable

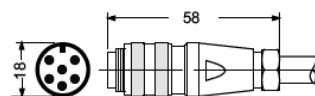

6 pin DIN male connector
Part No. 370 372

Housing: Zinc, nickel plated
Termination: Solder
Contact insert: Silver plated
Cable clamp: PG 7
Cable-Ø: 6 mm

Mating female connector M16

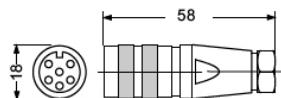

6 pin DIN female connector
Part No. 370 623

Accessories

Accessories	Part No.
Ring magnet OD33, Standard	201 542-2
U-Magnet OD33	251 416-2
Ring magnet OD25,4	400 533
6 pol. female cable connector M16	370 623
O-Ring 21,89 x 2,62	560 705
O-Ring 15,3 x 2,2 FPM	401 133
Backup ring	560 629

From F-No. 0546 xxxx LD-Analogue sensors are adjustable with following servicetools:
Handheld-Programmer G-Analogue 253 294
PC-Programmer G-Analogue incl. power supply 253 145
(100-240 VAC/24 VDC), cable and programming software (CD)



Temposonics

AN AMPHENOL COMPANY

UNITED STATES
Temposonics, LLC
Americas & APAC Region
3001 Sheldon Drive
Cary, N.C. 27513
Phone: +1 919 677-0100
E-mail: info.us@temposonics.com

GERMANY
Temposonics
GmbH & Co. KG
EMEA Region & India
Auf dem Schüffel 9
58513 Lüdenscheid
Phone: +49 2351 9587-0
E-mail: info.de@temposonics.com

ITALY
Branch Office
Phone: +39 030 988 3819
E-mail: info.it@temposonics.com

FRANCE
Branch Office
Phone: +33 6 14 060 728
E-mail: info.fr@temposonics.com

UK
Branch Office
Phone: +44 79 21 83 05 86
E-mail: info.uk@temposonics.com

SCANDINAVIA
Branch Office
Phone: +46 70 29 91 281
E-mail: info.sca@temposonics.com

CHINA
Branch Office
Phone: +86 21 2415 1000 / 2415 1001
E-mail: info.cn@temposonics.com

JAPAN
Branch Office
Phone: +81 3 6416 1063
E-mail: info.jp@temposonics.com

Document Part Number:

05012010e



temposonics.com

© 2021 Temposonics, LLC – all rights reserved. Temposonics, LLC and Temposonics GmbH & Co. KG are subsidiaries of Amphenol Corporation. Except for any third party marks for which attribution is provided herein, the company names and product names used in this document may be the registered trademarks or unregistered trademarks of Temposonics, LLC or Temposonics GmbH & Co. KG. Detailed trademark ownership information is available at www.temposonics.com/trademarkownership.