

Data Sheet

E-Series ET Start/Stop

Magnetostrictive Linear Position Sensors

- High operating temperature
- Compact sensor housing
- ATEX/UK Ex/IECEX/CEC/NEC/CCC certified

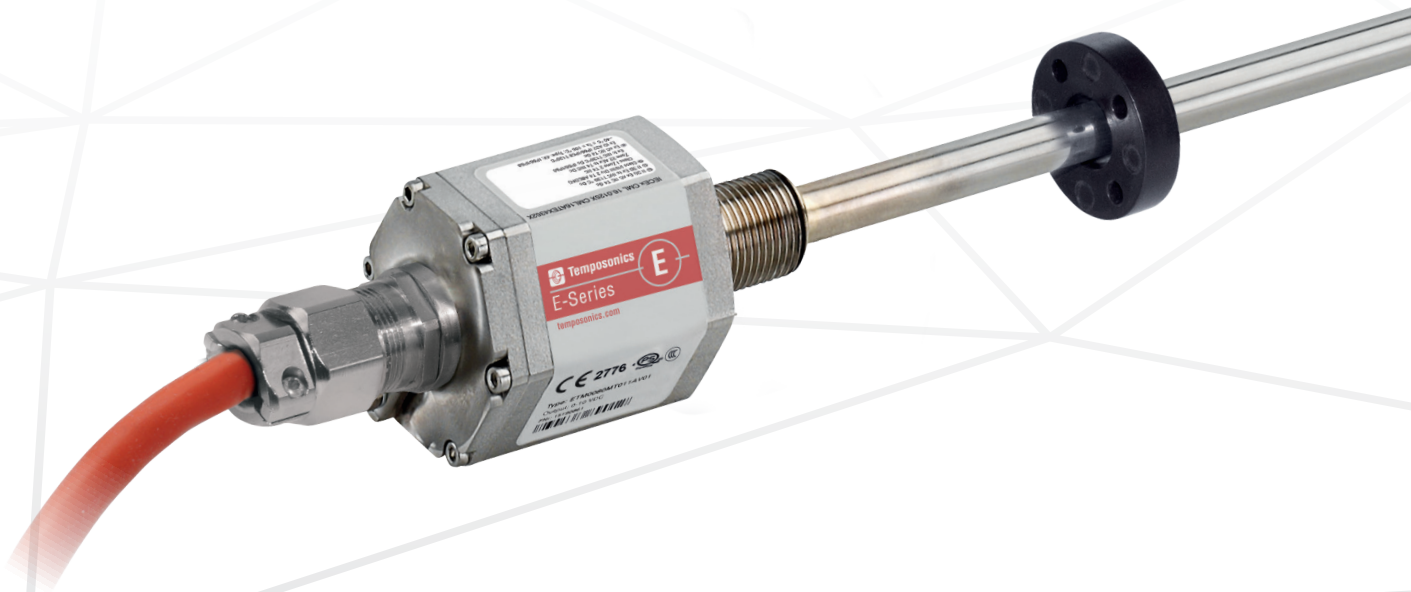

MEASURING TECHNOLOGY

The absolute, linear position sensors provided by Temposonics rely on the company's proprietary magnetostrictive technology, which can determine position with a high level of precision and robustness. Each Temposonics® position sensor consists of a ferromagnetic waveguide, a position magnet, a strain pulse converter and a supporting electronics. The magnet, connected to the object in motion in the application, generates a magnetic field at its location on the waveguide. A short current pulse is applied to the waveguide. This creates a momentary radial magnetic field and torsional strain on the waveguide. The momentary interaction of the magnetic fields releases a torsional strain pulse that propagates the length of the waveguide. When the ultrasonic wave reaches the beginning of the waveguide it is converted into an electrical signal. Since the speed of the ultrasonic wave in the waveguide is precisely known, the time required to receive the return signal can be converted into a linear position measurement with both high accuracy and repeatability.

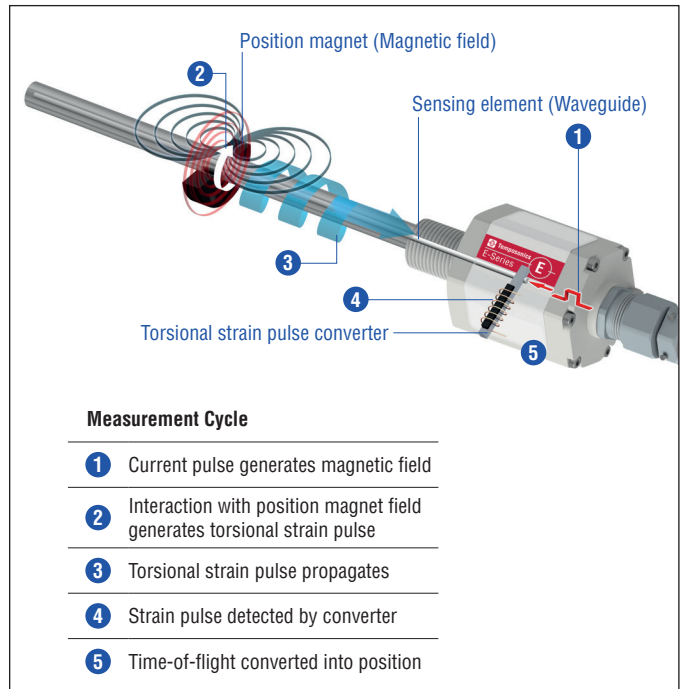

Fig. 1: Time-of-flight based magnetostrictive position sensing principle

ET SENSOR

Robust, non-contact and wear free, the Temposonics linear position sensors provide best durability and accurate position measurement solutions in harsh industrial environments. The position measurement accuracy is tightly controlled by the quality of the waveguide which is manufactured by Temposonics. The position magnet is mounted on the moving machine part and travels contactlessly over the sensor rod with the built-in waveguide.

ET sensor specifications:

- High operating temperature up to +105 °C (+221 °F)
- Compact sensor housing
- ATEX/UK Ex/IECEX/CEC/NEC/CCC certified
- Sensor parameters upload function

Certification
⊕ II 3G Ex nC IIC T4 Gc
⊕ II 3D Ex tc IIIC T130 °C Dc
⊕ Class I/II/III Div 2 T4 ABCDFG Class I Zone 2 T4 IIC Zone 22 AEx tc T4 IIIC Dc Ex tc IIIC T130°C Dc IP66/IP68
⊕ Ex nC IIC T4 Gc Ex tD A22 IP66/IP68 T130°C -40 °C ≤ Ta ≤ 105 °C; Type: 4X; IP66/IP68

Fig. 2: Certification of Temposonics® ET (version A and E)



Fig. 3: Typical application: Metal processing

TECHNICAL DATA

Output									
Start/Stop	RS-422 differential signal Serial parameter upload available for: Stroke length, offset, gradient, status, serial number and manufacturer number								
Measured value	Position								
Measurement parameters									
Resolution	Controller dependent								
Cycle time	Controller and stroke length dependent Recommendation: <table border="1"> <tr> <td>Stroke length</td> <td>≤ 1000 mm (40 in.)</td> <td>≤ 2000 mm (79 in.)</td> <td>≤ 3000 mm (118 in.)</td> </tr> <tr> <td>Cycle time</td> <td>0.5 ms</td> <td>0.9 ms</td> <td>1.25 ms</td> </tr> </table>	Stroke length	≤ 1000 mm (40 in.)	≤ 2000 mm (79 in.)	≤ 3000 mm (118 in.)	Cycle time	0.5 ms	0.9 ms	1.25 ms
Stroke length	≤ 1000 mm (40 in.)	≤ 2000 mm (79 in.)	≤ 3000 mm (118 in.)						
Cycle time	0.5 ms	0.9 ms	1.25 ms						
Linearity ¹	≤ ±0.02 % F.S. (minimum ±60 μm)								
Repeatability	≤ ±0.005 % F.S. (minimum ±20 μm) typical								
Operating conditions									
Operating temperature	-40...+105 °C (-40...+221 °F)								
Humidity	90 % relative humidity, no condensation								
Ingress protection	With FEP cable (part no. 530 112): IP66 With silicone cable (part no. 530 113): IP68 (2 bar (29 psi) @ 30 min)								
Shock test	100 g (single shock), IEC standard 60068-2-27								
Vibration test	20 g/10...2000 Hz, IEC standard 60068-2-6 (excluding resonant frequencies)								
EMC test	Electromagnetic emission according to EN 61000-6-3 Electromagnetic immunity according to EN 61000-6-2 The ET sensors fulfill the requirements of the EMC directives 2014/30/EU, UKSI 2016 No. 1091 and TR CU 020/2011								
Operating pressure	Up to 350 bar (5076 psi)								
Magnet movement velocity ²	Any								
Design/Material									
Sensor electronics housing/flange	Stainless steel 1.4305 (AISI 303); option: Stainless steel 1.4404 (AISI 316L)								
Sensor rod	Stainless steel 1.4306 (AISI 304L); option: Stainless steel 1.4404 (AISI 316L)								
RoHS compliance	The used materials are compliant with the requirements of EU directive 2011/65/EU and EU regulation 2015/863 as well as UKSI 2012 No. 3032								
Stroke length	50...3000 mm (2...118 in.)								
Mechanical mounting									
Mounting position	Any								
Mounting instruction	Please consult the technical drawings on page 4 and the operation manual (document number: 551677)								
Electrical connection									
Connection type	Cable outlet								
Operating voltage	+24 VDC (-15/+20 %)								
Ripple	≤ 0.28 V _{pp}								
Current consumption	Maximum 50 mA								
Dielectric strength	700 VDC (DC ground to machine ground)								
Polarity protection	Up to -30 VDC								
Overvoltage protection	Up to ≤ 32 VDC								

1/ With position magnet # 251 416-2

2/ If there is contact between the moving magnet including the magnet holder and the sensor rod, make sure that the maximal speed of the moving magnet is ≤ 1 m/s (Ex requirement due to ESD [Electro Static Discharge])

TECHNICAL DRAWING

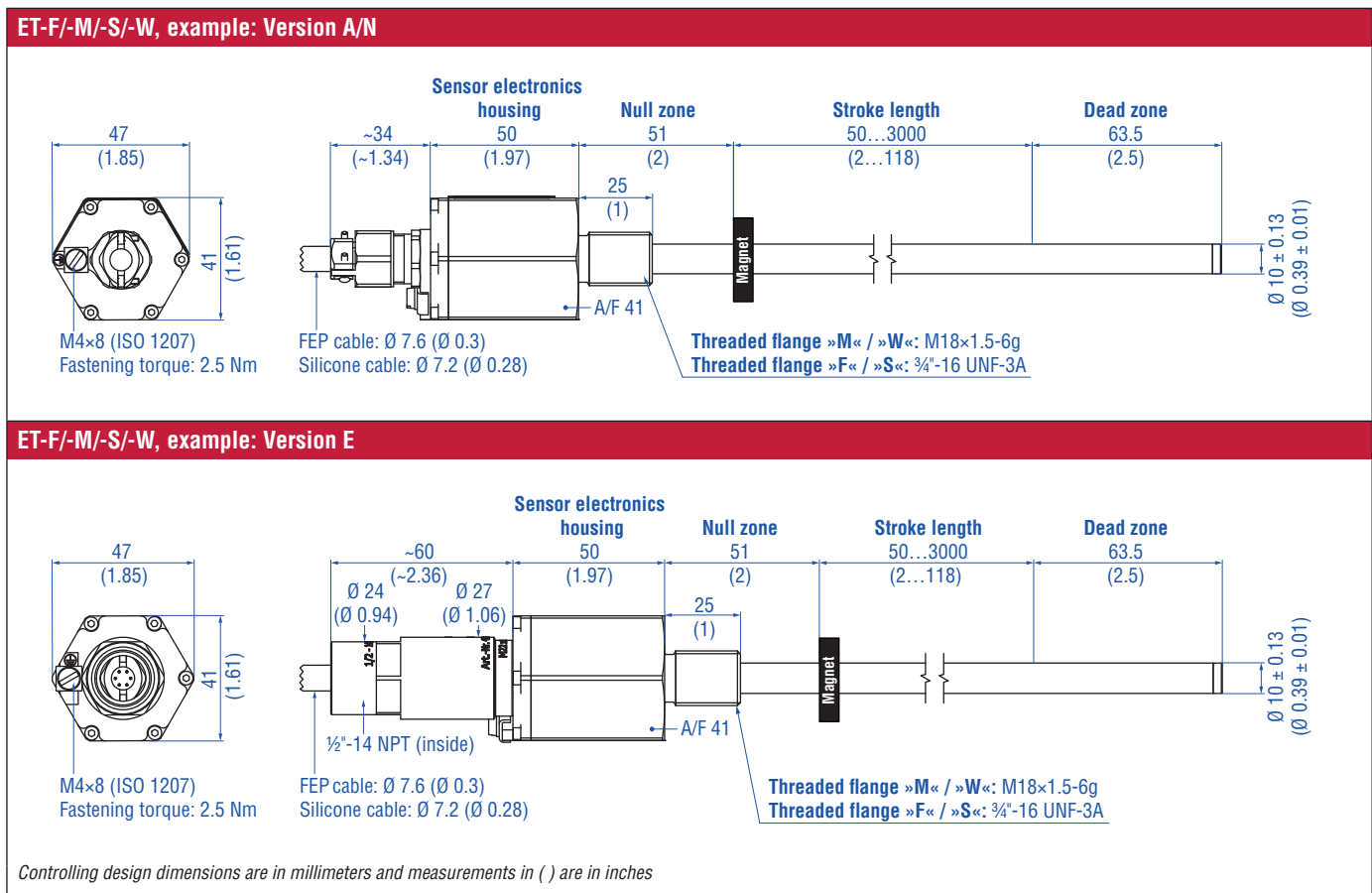

Fig. 4: Temposonics® ET with ring magnet

CONNECTOR WIRING

TXX/VXX		
Signal + power supply		
Cable	Color	Function
	GY	Stop (-)
	PK	Stop (+)
	YE	Start (+)
	GN	Start (-)
	BN	+24 VDC (-15/+20 %)
	WH	DC Ground (0 V)

Fig. 5: Connector wiring TXX/VXX

FREQUENTLY ORDERED ACCESSORIES – GENERAL – Additional options available in our [Accessories Catalog](#)  551444

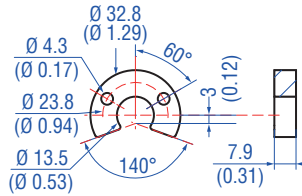
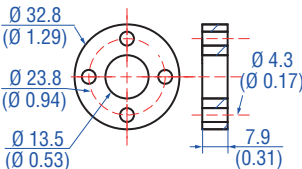
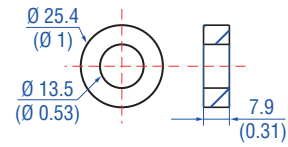
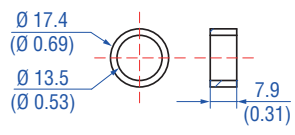
Position magnets			
			
<p>U-magnet OD33 Part no. 251 416-2</p> <p>Material: PA ferrite GF20 Weight: Approx. 11 g Surface pressure: Max. 40 N/mm² Fastening torque for M4 screws: 1 Nm Operating temperature: -40...+105 °C (-40...+221 °F)</p>	<p>Ring magnet OD33 Part no. 201 542-2</p> <p>Material: PA ferrite GF20 Weight: Approx. 14 g Surface pressure: Max. 40 N/mm² Fastening torque for M4 screws: 1 Nm Operating temperature: -40...+105 °C (-40...+221 °F)</p>	<p>Ring magnet OD25.4 Part no. 400 533</p> <p>Material: PA ferrite Weight: Approx. 10 g Surface pressure: Max. 40 N/mm² Operating temperature: -40...+105 °C (-40...+221 °F)</p>	<p>Ring magnet OD17.4 Part no. 401 032</p> <p>Material: PA neobond Weight: Approx. 5 g Surface pressure: Max. 20 N/mm² Operating temperature: -40...+105 °C (-40...+221 °F)</p>

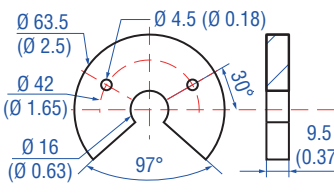
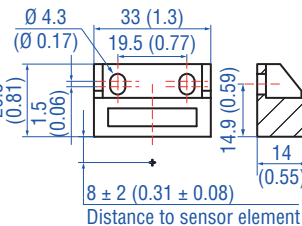
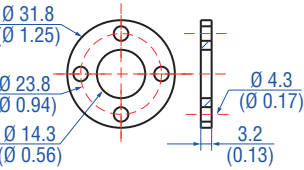
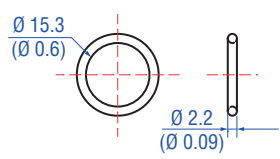
Position magnets	Magnet spacer	O-ring	
			
<p>U-magnet OD63.5 Part no. 201 553</p> <p>Material: PA 66-GF30, magnets compound-filled Weight: Approx. 26 g Surface pressure: 20 N/mm² Fastening torque for M4 screws: 1 Nm Operating temperature: -40...+75 °C (-40...+167 °F)</p>	<p>Block magnet L Part no. 403 448</p> <p>Material: Plastic carrier with hard ferrite magnet Weight: Approx. 20 g Fastening torque for M4 screws: 1 Nm Operating temperature: -40...+75 °C (-40...+167 °F)</p> <p>This magnet may influence the sensor performance specifications for some applications.</p>	<p>Magnet spacer Part no. 400 633</p> <p>Material: Aluminum Weight: Approx. 5 g Surface pressure: Max. 20 N/mm² Fastening torque for M4 screws: 1 Nm</p>	<p>O-ring for threaded flange M18×1.5-6g Part no. 401 133</p> <p>Material: Fluoroelastomer Durometer: 75 ± 5 Shore A Operating temperature: -40...+204 °C (-40...+400 °F)</p>

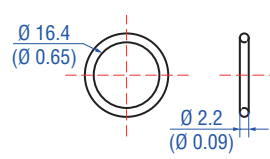
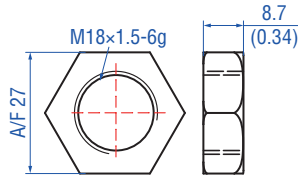
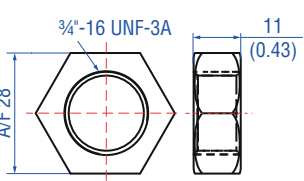
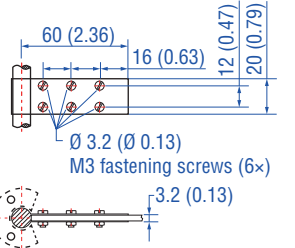
O-ring	Mounting accessories		O-ring
			
<p>O-ring for threaded flange ¾"-16 UNF-3A Part no. 560 315</p> <p>Material: Fluoroelastomer Durometer: 75 ± 5 Shore A Operating temperature: -40...+204 °C (-40...+400 °F)</p>	<p>Hex jam nut M18×1.5-6g Part no. 500 018</p> <p>Material: Steel, zinc plated</p>	<p>Hex jam nut ¾"-16 UNF-3A Part no. 500 015</p> <p>Material: Steel, zinc plated</p>	<p>Fixing clip Part no. 561 481</p> <p>Application: Used to secure sensor rods (Ø 10 mm (Ø 0.39 in.)) when using an U-magnet or block magnet Material: Brass, non-magnetic</p>

FREQUENTLY ORDERED ACCESSORIES – GENERAL – Additional options available in our [Accessories Catalog](#)  [551444](#)

Cable

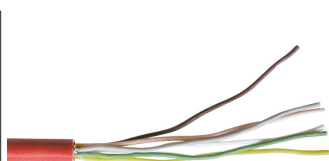
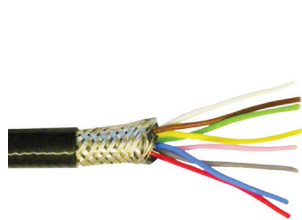

FEP cable
Part no. 530 112

Material: FEP jacket; black
Features: Twisted pair, shielded, flexible, high thermal resistance, mostly oil & acid resistant
Cable Ø: 7.6 mm (0.3 in.)
Cross section: $4 \times 2 \times 0.25 \text{ mm}^2$
Bending radius: $8 - 10 \times D$ (fixed installation)
Operating temperature: $-100...+180 \text{ }^\circ\text{C}$ ($-148...+356 \text{ }^\circ\text{F}$)

Silicone cable
Part no. 530 113

Material: Silicone jacket; red
Features: Twisted pair, shielded, highly flexible, halogen free, high thermal resistance
Cable Ø: 7.2 mm (0.28 in.)
Cross section: $3 \times 2 \times 0.25 \text{ mm}^2$
Bending radius: $5 \times D$ (fixed installation)
Operating temperature: $-50...+180 \text{ }^\circ\text{C}$ ($-58...+356 \text{ }^\circ\text{F}$)

Controlling design dimensions are in millimeters and measurements in () are in inches

ORDER CODE

1	2	3	4	5	6	7	8	9	10	11	12	13	14	15
E	T										1		R	3
a		b	c					d			e	f	g	

a	Sensor model
E T	Rod

b	Design
ET rod-style sensor with housing and sensor rod material stainless steel 1.4404 (AISI 316L)	
F	Threaded flange ¾"-16 UNF-3A
W	Threaded flange M18×1.5-6g
ET rod-style sensor with housing material stainless steel 1.4305 (AISI 303) and sensor rod material stainless steel 1.4306 (AISI 304L)	
M	Threaded flange M18×1.5-6g
S	Threaded flange ¾"-16 UNF-3A

c	Stroke length
X X X X M	0050...3000 mm
Standard stroke length (mm)	
	Ordering steps
50... 500 mm	5 mm
500... 750 mm	10 mm
750... 1000 mm	25 mm
1000... 2500 mm	50 mm
2500... 3000 mm	100 mm
X X X X U	002.0...118.0 in.
Standard stroke length (in.)	
	Ordering steps
2... 20 in.	0.2 in.
20... 30 in.	0.5 in.
30... 40 in.	1.0 in.
40... 100 in.	2.0 in.
100... 118 in.	4.0 in.
Non-standard stroke lengths are available; must be encoded in 5 mm/0.1 in. increments	

d	Connection type
T X X	T01...T10 (1...10 m) XX m FEP cable (part no. 530 112) T03...T33 (3...33 ft.) XX ft. FEP cable (part no. 530 112) See "Frequently ordered accessories" for cable specifications.
V X X	V01...V10 (1...10 m.) XX m silicone cable (part no. 530 113) V03...V33 (3...33 ft.) XX ft. silicone cable (part no. 530 113) See "Frequently ordered accessories" for cable specifications.
Encode in meters if using metric stroke length. Encode in feet if using US customary stroke length.	

e	Operating voltage
1	+24 VDC (-15/+20 %)

f	Version (see "Certification of Temposonics® ET (version A and E)" on page 2 for further information)
A	ATEX/UK Ex/IECEX/CEC/NEC/CCC
E	ATEX/UK Ex/IECEX/CEC/NEC/CCC with ½" NPT adapter
N	Not approved

NOTICE	
Version E (section f) is only available with design »M« and »S« (section b).	

g	Output
R 3	Start/Stop with sensor parameters upload function

DELIVERY



Sensor

Accessories have to be ordered separately

Manuals, Software & 3D Models available at:
www.temposonics.com

UNITED STATES
Temposonics, LLC
Americas & APAC Region
3001 Sheldon Drive
Cary, N.C. 27513
Phone: +1 919 677-0100
E-mail: info.us@temposonics.com

GERMANY
Temposonics
GmbH & Co. KG
EMEA Region & India
Auf dem Schüffel 9
58513 Lüdenscheid
Phone: +49 2351 9587-0
E-mail: info.de@temposonics.com

ITALY
Branch Office
Phone: +39 030 988 3819
E-mail: info.it@temposonics.com

FRANCE
Branch Office
Phone: +33 6 14 060 728
E-mail: info.fr@temposonics.com

UK
Branch Office
Phone: +44 79 21 83 05 86
E-mail: info.uk@temposonics.com

SCANDINAVIA
Branch Office
Phone: +46 70 29 91 281
E-mail: info.sca@temposonics.com

CHINA
Branch Office
Phone: +86 21 3405 7850
E-mail: info.cn@temposonics.com

JAPAN
Branch Office
Phone: +81 3 6416 1063
E-mail: info.jp@temposonics.com

Document Part Number:
551676 Revision E (EN) 05/2023



temposonics.com